

 HONDA INSTALLATION INSTRUCTIONS	Accessory CASSETTE PLAYER ATTACHMENT KIT	Application 2000 PRELUDE	Publications No. All 21000
			Issue Date SEP 1999

PARTS LIST

Cassette Player Attachment:
P/N 08B10-S30-100F

Side bracket (R)



Side bracket (L)



2 Wire clips



Cushion
(not used)



2 Washer-screws,
5 x 8 mm



Spacer



Cassette Player (sold separately):
P/N 08A03-581-111

Cassette player



4 Wire ties
(not used)

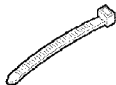

4 Washer-screws,
4 x 12 mm



TOOLS AND SUPPLIES REQUIRED

Phillips screwdriver
Flat-tip screwdriver
Shop towel
Utility knife
Contact cleaner

INSTALLATION

Customer Information: The information in this installation instruction is intended for use only by skilled technicians who have the proper tools, equipment, and training to correctly and safely add equipment to your car. These procedures should not be attempted by "do-it-yourselfers."

1. Make sure you have the anti-theft code for the radio, then write down the frequencies for the preset buttons.
2. Disconnect the negative cable from the battery.
3. Apply the parking brake, and move the shift lever to first gear (A/T only). Using a shop towel around a screwdriver, release the eight clips securing the center panel, and remove it. Take care not to damage the clips.

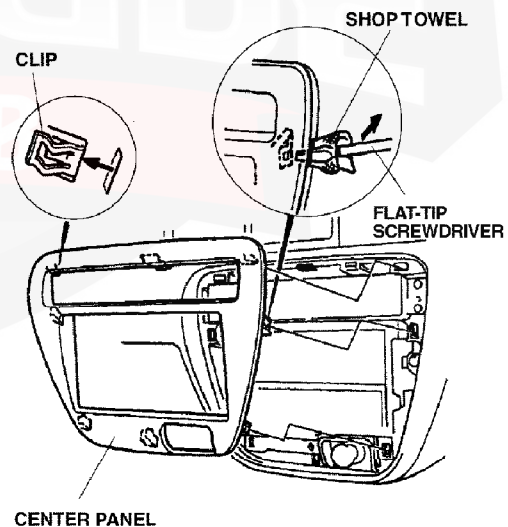

- Remove the audio unit by removing the four self-tapping screws, and disconnecting the 16-pin connector and the antenna lead.

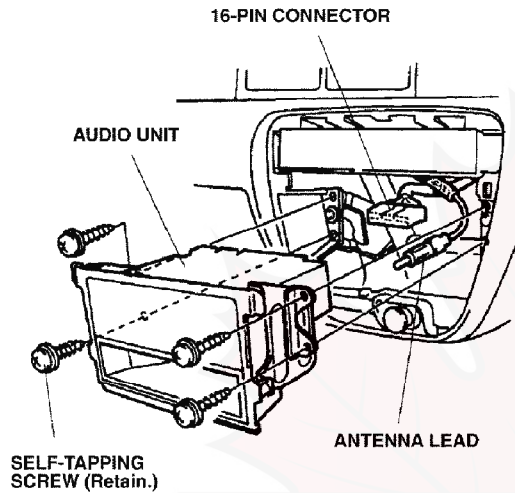

- Remove and retain the four screws that fasten the audio unit to the audio bracket, and separate the audio unit from the audio bracket.

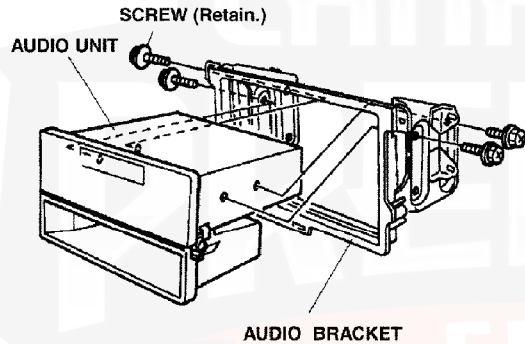

- Remove the pocket from the audio unit (two screws).

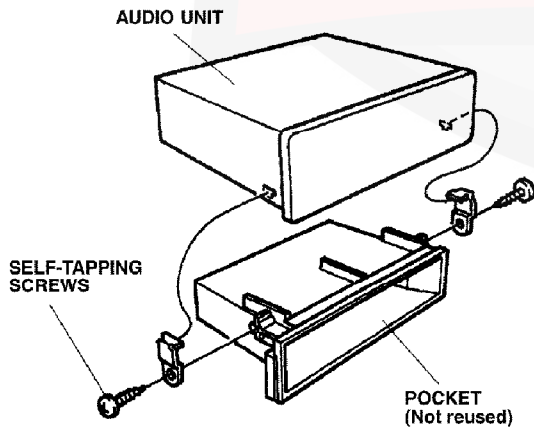

- Using a utility knife, cut out the marked area from the audio bracket.

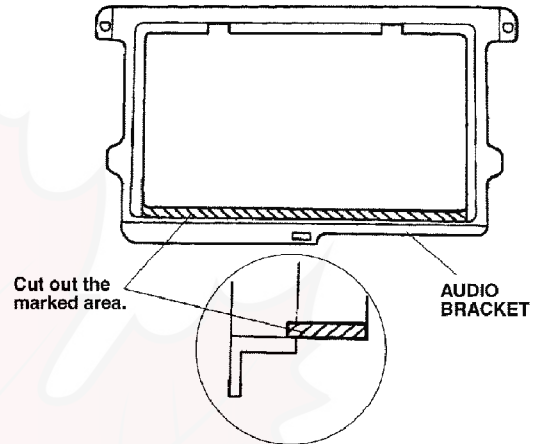

- Remove the right and left side brackets from the audio bracket by removing the two self-tapping screws from each side bracket.

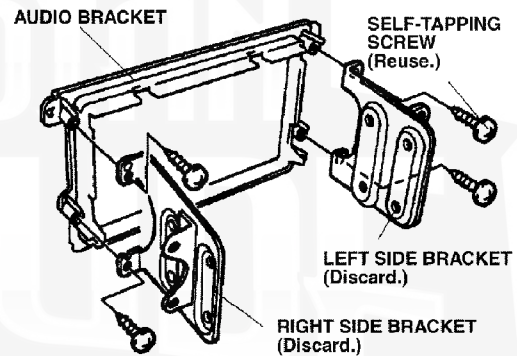

- Position the new right and left side brackets on the audio bracket, and install the four self-tapping screws you just removed.

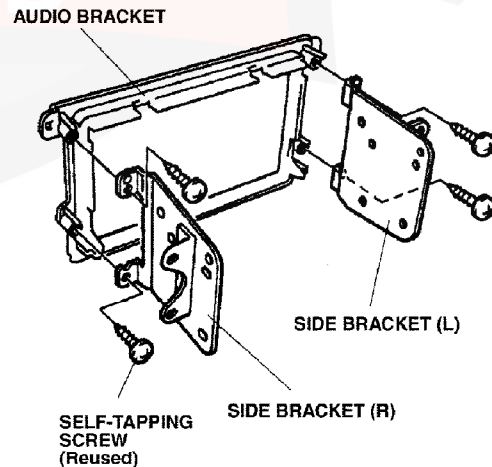

10. Thoroughly clean the bonding surface of the cassette player where the spacer will attach. Remove the adhesive backing from the spacer, and attach it to the cassette player.

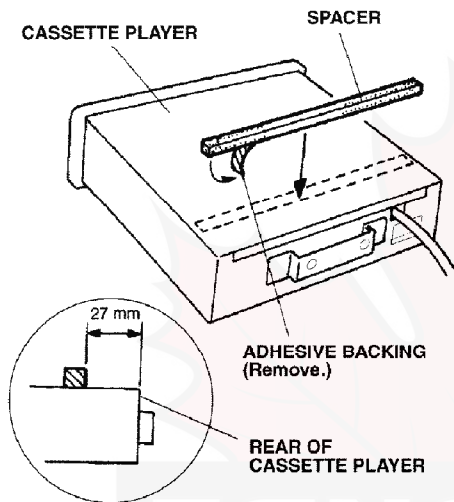

11. Slide the audio unit and the cassette player together, and install the four screws you removed in step 5 and the four 4 x 12 mm screws supplied with the cassette player. Put the cassette player on the bottom.

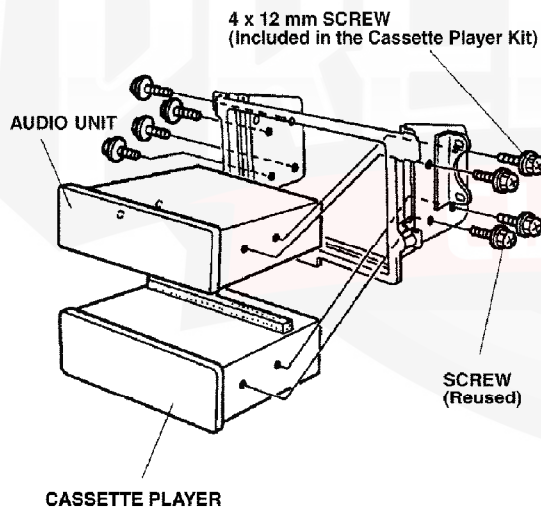

12. Position the wire clips on the rear of the cassette player, and install the two 5 x 8 mm washer-screws.

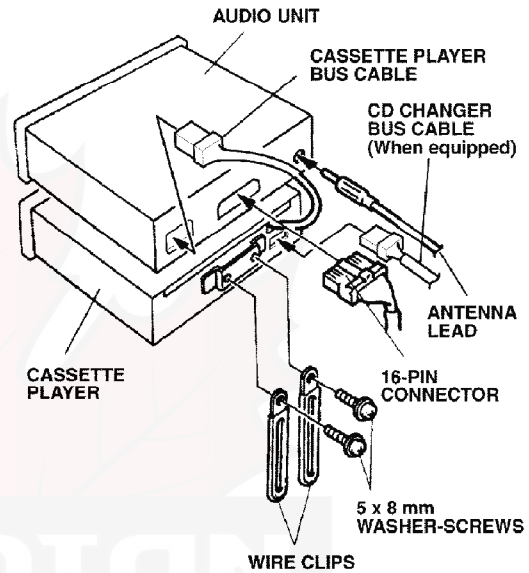

13. Plug the bus connector from the cassette player into the rear of the audio unit.

- The 16-pin connector and antenna lead will be plugged into the rear of the audio unit later.
- The bus connector from the CD changer will be plugged into the rear of the cassette player later.

14. Bundle up the cassette player bus cable, and secure it with the two wire clips.

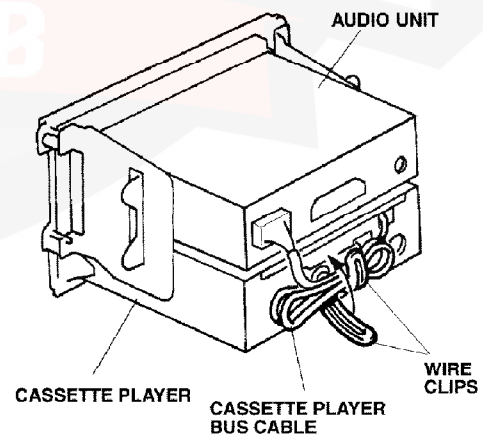

15. Plug the 16-pin connector and the antenna lead into the rear of the audio unit. (If the vehicle is equipped with a CD changer, plug the CD changer bus connector into the back of the cassette player.)

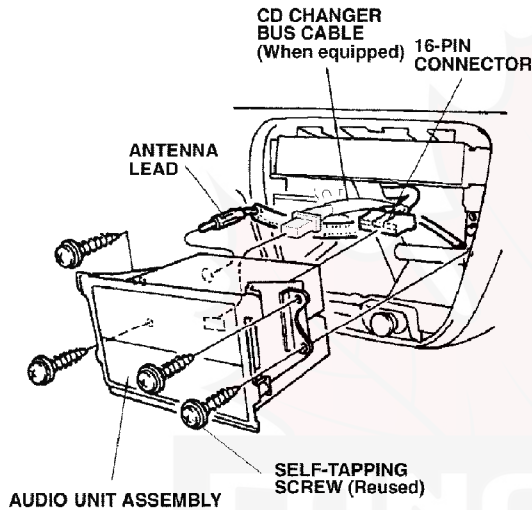

16. Install the audio unit assembly into the instrument panel using the four self-tapping screws you removed in step 4. Take care not to pinch the wire harnesses and cables.
17. Reinstall the center panel.
18. Check that all wire harnesses are routed properly and all connectors are plugged in.
19. Reconnect the negative cable to the battery.
20. Enter the customer's radio anti-theft code, and reset the radio station presets.
21. Reset the clock.
22. Check operation of the cassette player according to the vehicle Owner's Manual.