

 HONDA INSTALLATION INSTRUCTIONS	Accessory	Application	Publications No. All 21017
	REAR WING SPOILER	2000 PRELUDE	Issue Date SEP 1999

PARTS LIST

Rear wing spoiler

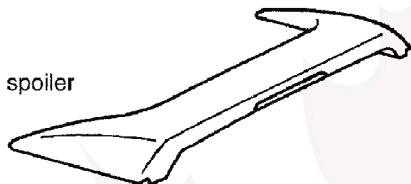

Left trunk spring



Spoiler harness



Template



4 Washer-bolts, 6 x 12 mm



8 Wire ties

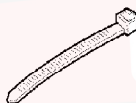

4 Butyl washers



TOOLS AND SUPPLIES REQUIRED

Phillips screwdriver
 Eye protection (face shield, safety goggles, etc.)
 Drill
 3 mm, 6 mm, 8 mm and 10 mm Bits
 10 mm Socket
 Ratchet
 File
 Center punch
 Water soluble felt-tip pen
 Template
 Trunk spring tool: P/N 08M10-SS0-100
 Heavy gloves
 Torque wrench
 Pliers
 Side cutters
 Clip remover
 Black insulation tape
 Touch-up paint
 Piece of wire

INSTALLATION

Customer Information: The information in this installation instruction is intended for use only by skilled technicians who have the proper tools, equipment, and training to correctly and safely add equipment to your car. These procedures should not be attempted by "do-it-yourselfers."

1. Make sure the area to be covered is clean and has been waxed with a high-quality paste wax.
2. Make sure you have the anti-theft code for the radio, then write down the frequencies for the preset buttons.
3. Disconnect the negative cable from the battery.

4. Inside the trunk, locate the two identification holes on the trunk lid. If necessary, scrape away the seam sealant so you can see the outline of the holes. Mark and lightly center-punch the center of the holes. Repeat on the other side.

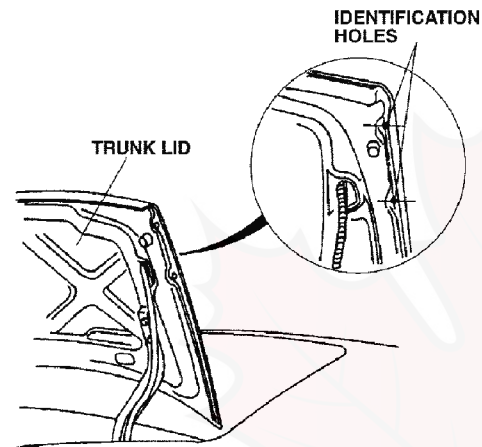

5. Have an assistant hold the trunk lid open. While wearing eye protection, drill an 8 mm hole through each mark:

Drill first with a 3 mm bit, then with a 6 mm bit, and finally with an 8 mm bit.

Remove all burrs and metal shavings, and apply touch-up paint to the edges of the holes.

Repeat on the other side.

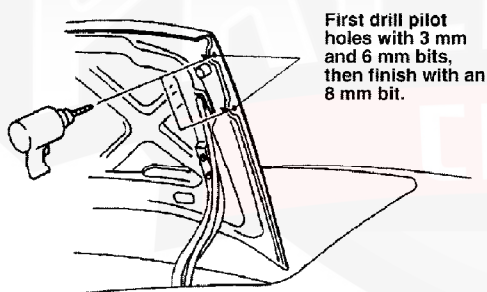

6. Close the trunk lid. Position the template, printed side up, at the passenger's side edge of the trunk lid. Align the two outer holes in the template with the two holes in the trunk lid. Using a felt-tip pen, mark the trunk lid as indicated on the template. The left side of the trunk lid does not need a hole; mark only the right side for the spoiler harness. Remove the template, and lightly center-punch the mark.

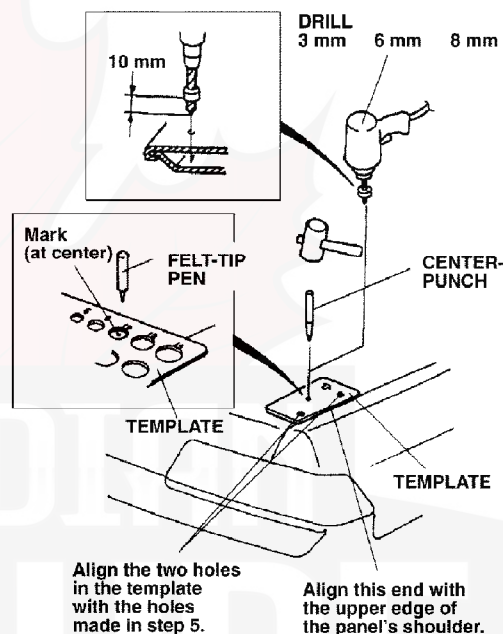

7. While wearing eye protection, drill a 10 mm hole at the center-punched mark through the outer skin of the trunk lid; do not drill through the inner panel:

Drill first with a 3 mm bit, next with a 6 mm bit, then with an 8 mm bit, and finally with a 10 mm bit.

Remove all burrs and metal shavings, and apply touch-up paint to the edge of the hole you drilled.

NOTE: This hole is for routing the spoiler harness through the trunk lid.

8. Hold the spoiler above the trunk, and route the spoiler harness down through the 10 mm hole you just drilled. Then route it through the rectangular hole as shown. If necessary, use a piece of wire to pull the spoiler harness. Install the four 6 x 12 mm bolts and four butyl washers, and carefully torque the bolts to 7 to 10 N·m (5 to 7 lb-ft).

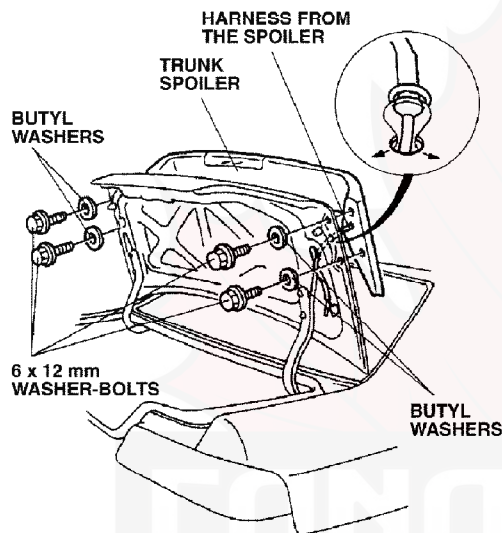

9. Remove the center clip.

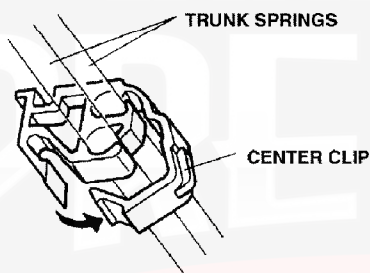

10. With an assistant holding the trunk lid open, remove the old trunk springs from the trunk hinge arms using the special tool. Wear heavy gloves to protect your hands, and pull the special tool slowly and carefully toward you.

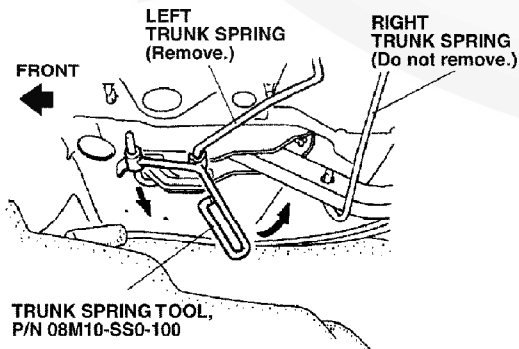

11. Install the new heavy-duty springs in the reverse order of removal:

Set the special tool on the unmarked end of each trunk spring.

Install the red-marked spring starting with the hole in the spring at the right (passenger's) side of the vehicle; install the yellow-marked spring starting on the left (driver's) side.

While wearing heavy gloves, rotate the tool as you pull it toward you.

Set the springs into the first notch (original position) of the hinge arms.

Reinstall the center clip on the trunk springs.

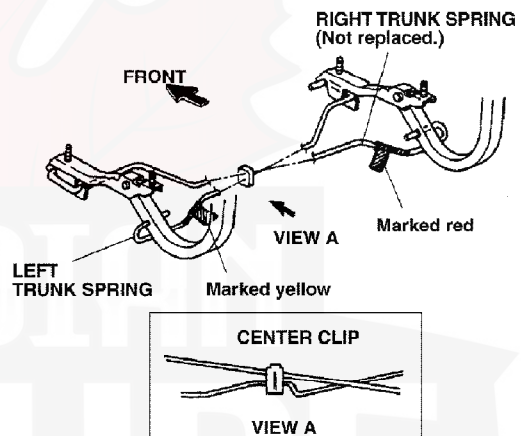

Routing the Wire Harness

12. Disconnect the high-mount brake light 2-pin connector. Route the spoiler harness over the trunk spring, and connect the spoiler harness 2-pin connector to the high-mount brake light harness 2-pin connector.

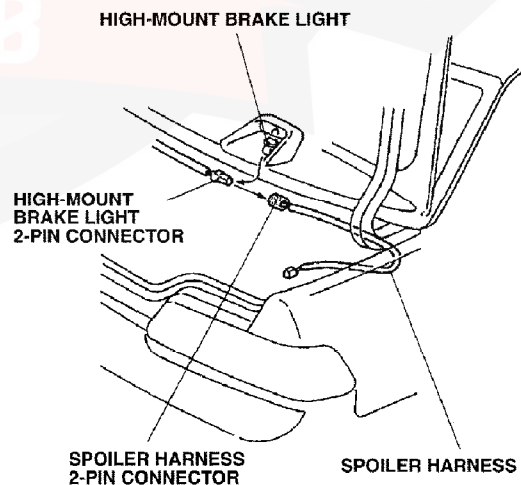

13. Connect the other 2-pin connector of the spoiler harness to the 2-pin connector on the harness from the trunk spoiler.

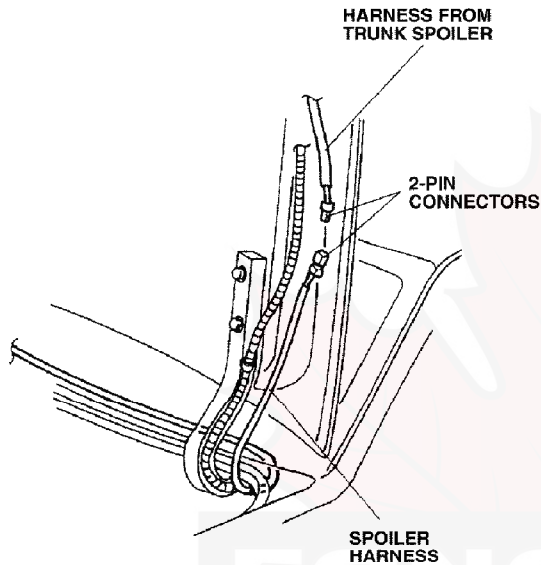

14. Secure the spoiler harness and the harness from the trunk spoiler to the vehicle harness with the eight wire ties in the areas shown.

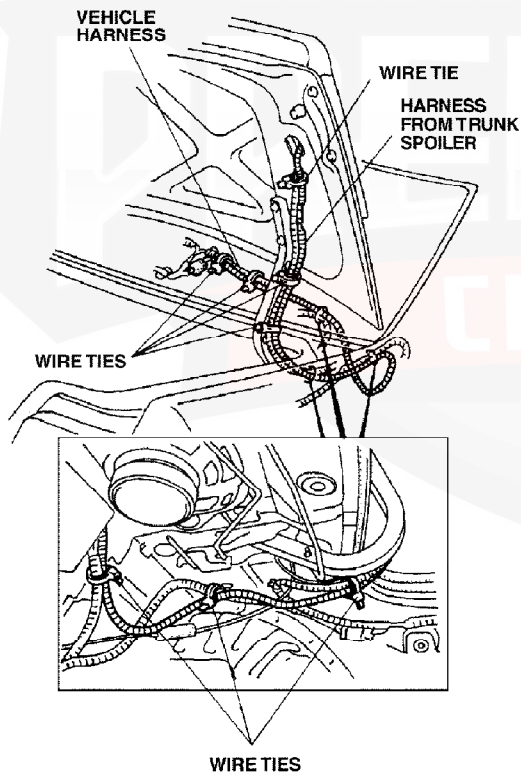

15. Check that all wire harnesses are routed properly and all connectors are plugged in.
16. Reinstall all removed parts.
17. Reconnect the negative cable to the battery.
18. Enter the customer's radio anti-theft code, and reset the radio station presets.
19. Reset the clock.
20. Check that the spoiler brake light comes on when the brake pedal is pressed.

USE AND CARE

Handle the spoiler with care; it is not designed to absorb impact.

Do not open the trunk lid by grasping the spoiler.

Check the spoiler mounts frequently, and retighten them if necessary.