



 1995 Service Manual
First Edition

Global

Downloaded from Canadian Prelude Club

PRELUDE
INFAMOUZ

INTRODUCTION

How to Use This Manual

This supplement contains information for the 1995 Prelude. Refer to following shop manuals for service procedures and data not included in this supplement.

Description	Code No.
PRELUDE MAINTENANCE, REPAIR and CONSTRUCTION 92	62SS000
PRELUDE SUPPLEMENT 93	62SS020
PRELUDE SUPPLEMENT 94	62SS021

The first page of each section is marked with a black tab that lines up with one of the thumb index tabs on this page. You can quickly find the first page of each section without looking through a full table of contents. The symbols printed at the top corner of each page can also be used as a quick reference system.

Special Information

▲WARNING

Indicates a strong possibility of severe personal injury or loss of life if instructions are not followed.

CAUTION:

Indicates a possibility of personal injury or equipment damage if instructions are not followed.

NOTE:

Gives helpful information.

CAUTION:

Detailed descriptions of standard workshop procedures, safety principles and service operations are not included. Please note that this manual contain warnings and cautions against some specific service methods which could cause PERSONAL INJURY, damage a vehicle or make it unsafe. Please understand that these warnings cannot cover all conceivable ways in which service, whether or not recommended by Honda, might be done, or of the possible hazardous consequences of every conceivable way, nor could Honda investigate all such ways. Anyone using service procedures or tools, whether or not recommended by Honda, must satisfy himself thoroughly that neither personal safety nor vehicle safety will be jeopardized.

All information contained in this manual is based on the latest product information available at the time of printing. We reserve the right to make changes at any time without notice. No part of this publication may be reproduced, stored in retrieval system, or transmitted, in any form by any means, electronic, mechanical, photocopying, recording, or otherwise, without the prior written permission of the publisher. This includes text, figures and tables.

marked sections are not included in this manual.
As sections with * include SRS components; special precautions are required, when servicing.

First Edition 1/95 112 pages
All Rights Reserved

HONDA MOTOR CO., LTD.
Service Publication Office

*General Info



Special Tools



Specifications

specs

Maintenance



Engine



Cooling



Fuel and Emissions



Transaxle



*Steering



Suspension



Brakes (Including ABS)



*Body



*Heater and Air Conditioning



*Electrical (Including SRS)



Outline of Model Changes

ITEM	DESCRIPTION	MODELS			REFERENCE SECTION
		93	94	95	
Engine	Added · H22A2 engine	○			—
	Added · H22A1 engine (KQ model) · Recommended engine oil SH grade		○		—
PGM-FI	Added · H22A2 engine	○			—
	Added · H22A1 engine (KQ model) Changed · Main wire harness		○		—
	Added · H23A1 engine (KM model)			○	11
Manual Transmission	Added · M2F5 manual transmission for H22A2 engine	○			—
	Changed · Countershaft clearance inspection · Reverse idler gear shaft bolt torque			○	13
Automatic Transmission	Modified · Circuit diagram Changed · Reverse idler gear shaft and holder · Main valve body assembly · Secondary shaft assembly · Clutch discs and pistons · Throttle control cable inspection and adjustment Discontinued · Right side cover protector		○		—
	Added · 1st clutch disc · Parking pin switch for KM model Changed · 1st-hold clutch plate · Transmission housing bolt torque			○	14
Steering (4WS)	Changed · Blinking interval of problem code indication patterns Deleted · No. 70 (IG1) of problem code		○		—
Body	Changed · Center console · Door construction Added · Rear emblem · Trunk spoiler with high mount brake light (KQ model VTEC)		○		—
	Changed · Front seat belt upper and lower anchor bolt construction · Sunroof seal holder mounting nuts Added · Knee bolster (KM model) · Door cylinder protector			○	20

ITEM	DESCRIPTION	MODELS			REFERENCE SECTION
		93	94	95	
Air Conditioning	Changed <ul style="list-style-type: none"> Refrigerant: Refrigerant HFC-134a (R-134a) 		○		—
	Changed <ul style="list-style-type: none"> Circuit diagram Relief valve cover of the Hadsys-mode spiral-type compressor (HS-090L) 			○	22
Electrical	Added <ul style="list-style-type: none"> H22A2 engine Interlock system (KQ model) Power door lock actuator (KQ model) SRS type I Changed <ul style="list-style-type: none"> Power supply circuit Dash lights brightness control unit (European model) Integrated control unit (KY model) 	○			—
	Added <ul style="list-style-type: none"> H22A1 engine (KQ model) New indicator light (some models) Ceiling/Spot light (KQ, KY models) SRS type III Changed <ul style="list-style-type: none"> Shift lever position indicator (luminescent gauges) Interlock system connector (KQ model) Brake/High mount brake light failure sensors Turn signal/Hazard flasher system circuits Dash lights brightness control controller locations (some models) Power windows driver's switch assembly Head light adjuster switch location Seat heater switch location Power mirror switch location Headlight washer switch location Adopted <ul style="list-style-type: none"> New main gauge (luminescent gauges) 		○		—
	Added (KM model) <ul style="list-style-type: none"> Clutch interlock switch for starting system Parking pin switch for interlock system Key-off timer for power windows Key-off timer for sunroof Changed (KM model) <ul style="list-style-type: none"> Shift lever position indicator circuit diagram Integrated control unit circuit diagram Changed <ul style="list-style-type: none"> Stereo sound system is now possible to replace the antenna tube Power mirror is now possible to replace the power mirror actuator 			○	23

General Information

Chassis and Engine Numbers..... 1-2

Identification Number Locations 1-4

Warning/Caution Label Locations 1-5

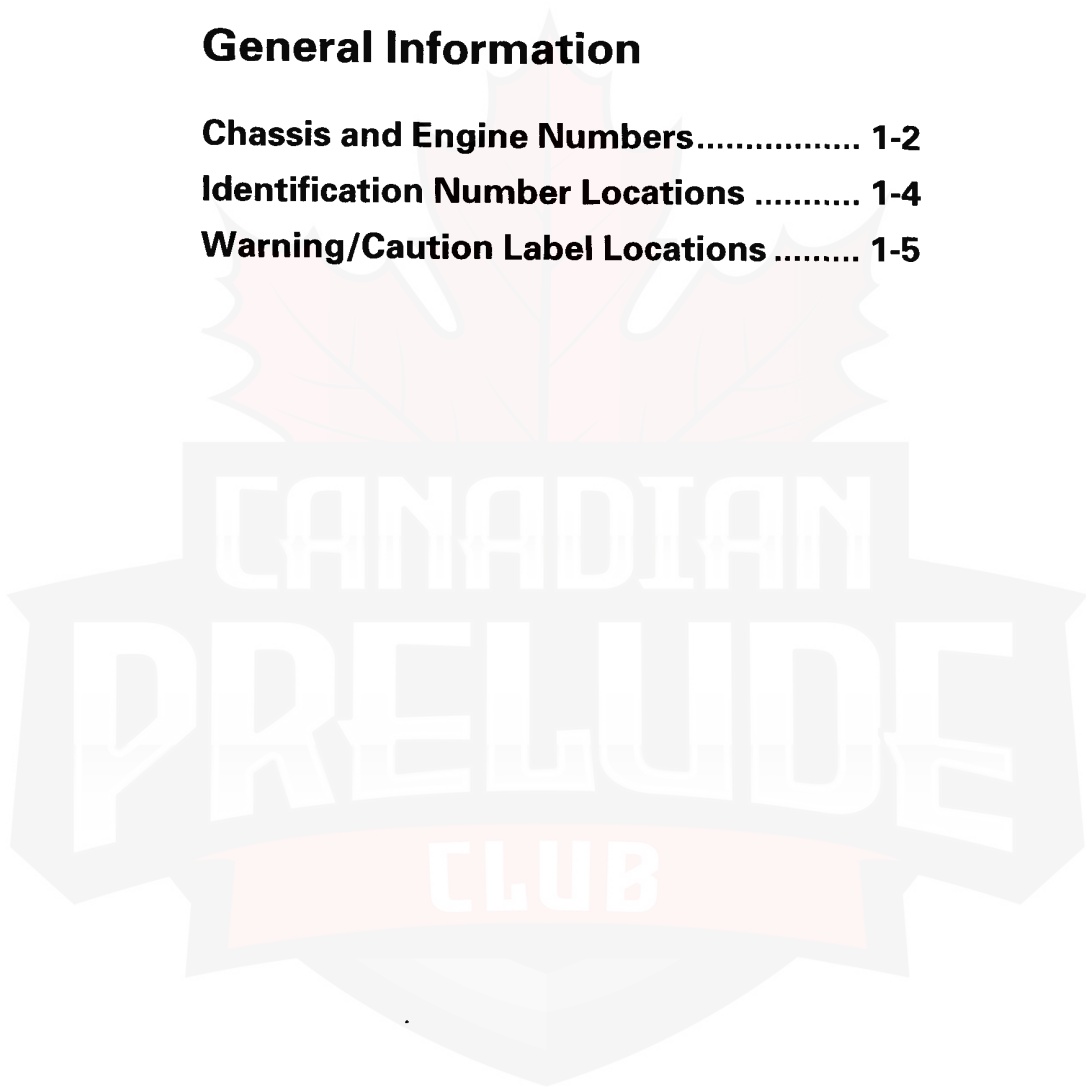

Chassis and Engine Numbers

European Model

Vehicle Identification Number

JHMBB1 1 8 0 0 C 2 00001

Manufacturer, Make and Type of Vehicle

JHM: HONDA MOTOR CO., LTD.
JAPAN
HONDA Passenger car

Line, Body and Engine Type

BB1: Prelude/H22A2
BB2: Prelude/H23A2
BB3: Prelude/F20A4

Body Type and Transmission Type

1: 2-door Coupe/5-speed Manual
2: 2-door Coupe/4-speed Automatic

Vehicle Grade (Series)

4: 2.0i
5: 2.3i
6: 2.3i with driver's and a front passenger's SRS airbag system
8: 2.2i-VTEC with driver's and a front passenger's SRS airbag system

Fixed Code

Auxiliary Number

Factory Code

C: Saitama Factory in Japan (Sayama)

Model Year

2: 1995 (BB1)
3: 1995 (BB2, BB3)

Serial Number

Engine Number

F20A4 - 9400001

Engine Type

F20A4: 2.0 l SOHC Sequential Multiport Fuel-injected engine with catalytic converter
H22A2: 2.2 l DOHC VTEC Sequential Multiport Fuel-injected engine with catalytic converter
H23A2: 2.3 l DOHC Sequential Multiport Fuel-injected engine with catalytic converter

Serial Number

F20A4: 9400001 ~
H22A2: 3000001 ~
H23A2: 4000001 ~

Transmission Number

M2F5 - 3000001

Transmission Type

M2F5: Manual with H22A2 engine
M2J4: Manual with F20A4 engine
M2K4: Manual with H23A2 engine
MP1A: Automatic

Serial Number

M2F5: 3000001
Except M2F5: 4000001

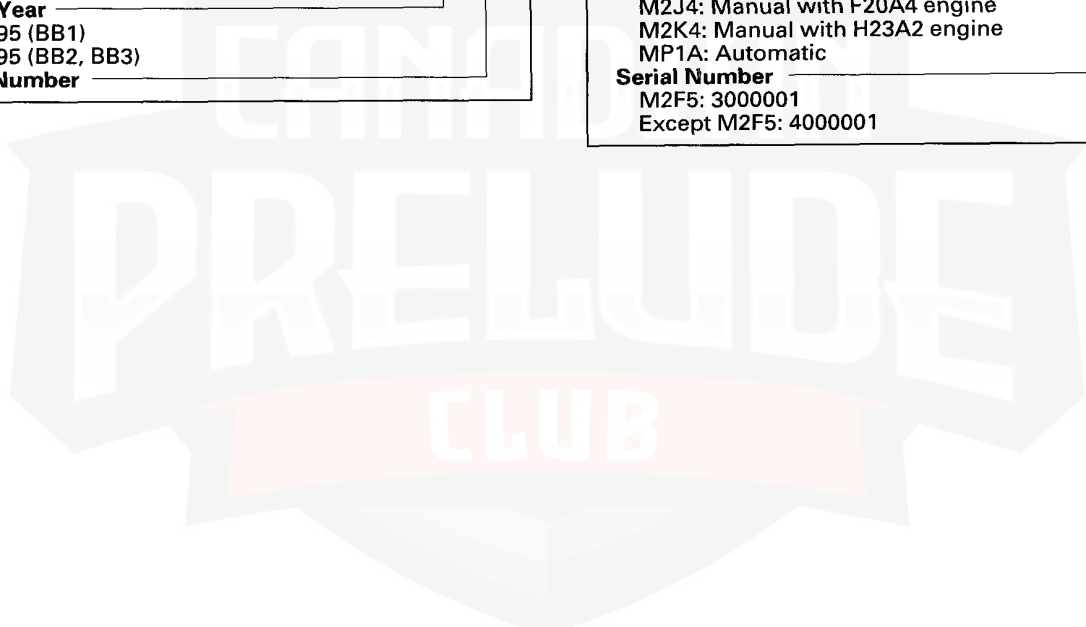



Except European Model

Vehicle Identification Number

JHMBA8 1 4 0 0 C 3 00001

Manufacturer, Make and**Type of Vehicle**

JHM: HONDA MOTOR CO., LTD.
JAPAN
HONDA, Passenger car

Line, Body and Engine Type

BA8: Prelude/F22A1, F22A2
BB1: Prelude/H22A1
BB2: Prelude/H23A1

Body Type and Transmission Type

1: 2-door Coupe/5-speed Manual
2: 2-door Coupe/4-speed Automatic

Vehicle Grade (Series)

4: S (KQ), Si (KT, KY, KM)
5: Si (KQ) and Si-SPECIAL (KQ)
7: VTI-R (KQ)

Fixed Code**Auxiliary Number or Production Year**

Auxiliary Number (Except KM): 0
Production Year (KM)
R: 1994
S: 1995

Factory Code

C: Saitama Factory in Japan (Sayama)

Model Year

2: 1995 (BB1)
3: 1995 (BA8, BB2)

Serial Number

Engine Number

F22A1-9490001

Engine Type

F22A1: 2.2 l SOHC Sequential Multiport Fuel-injected engine with catalytic converter (KQ)
F22A2: 2.2 l SOHC Sequential Multiport Fuel-injected engine without catalytic converter (KT/KY)
H22A1: 2.2 l DOHC VTEC Sequential Multiport Fuel-injected engine with catalytic converter (KQ)
H23A1: 2.3 l DOHC Sequential Multiport Fuel-injected engine with catalytic converter (KQ, KM)

Serial Number

F22A1: 9490001
F22A2: 9400001
H22A1: 1910001
H23A1: 4800001

Transmission Number

M2C4-4000001

Transmission Type

M2C4: Manual with F22A2 engine (KT/KY)
M2F5: Manual with H22A1 engine (KQ)
M2J4: Manual with F22A1 engine (KQ)
M2K4: Manual with H23A1 engine (KQ, KM)
MP1A: Automatic

Serial Number

M2F5: 3000001
Except M2F5: 4000001

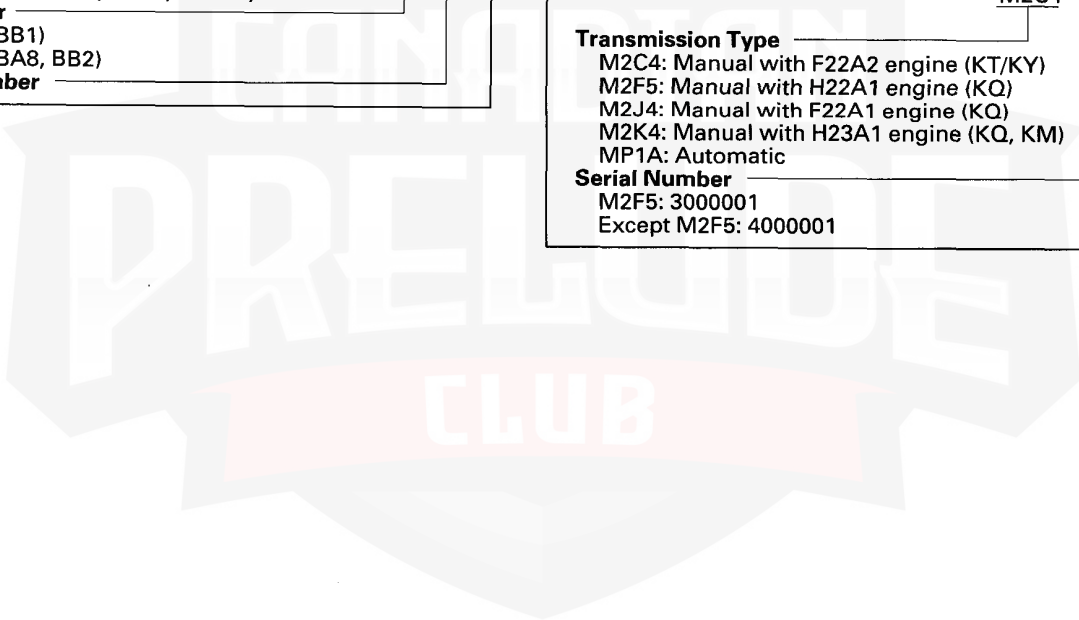

Identification Number Locations

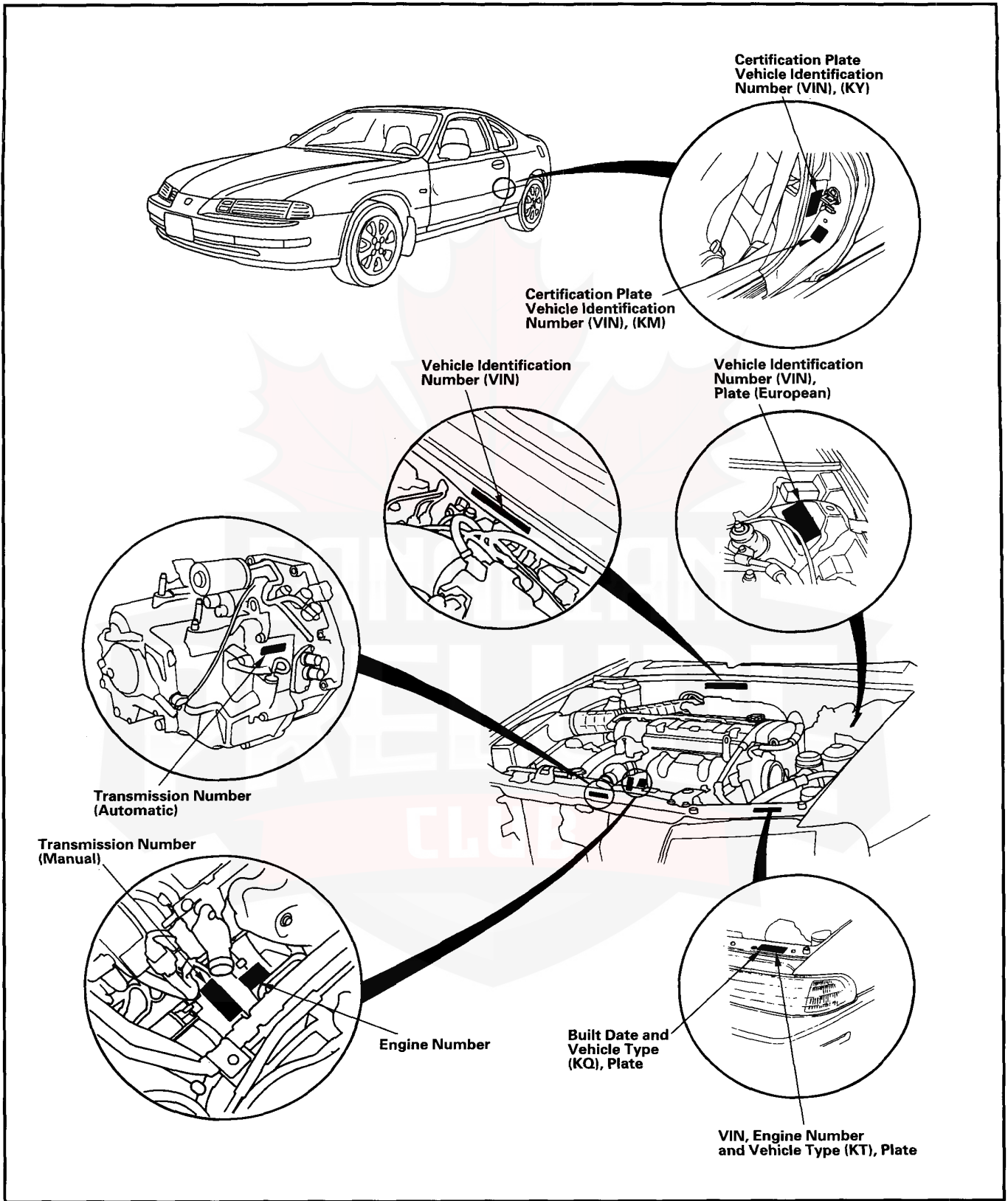

Warning/Caution Label Locations



SRS Airbag System Type III:

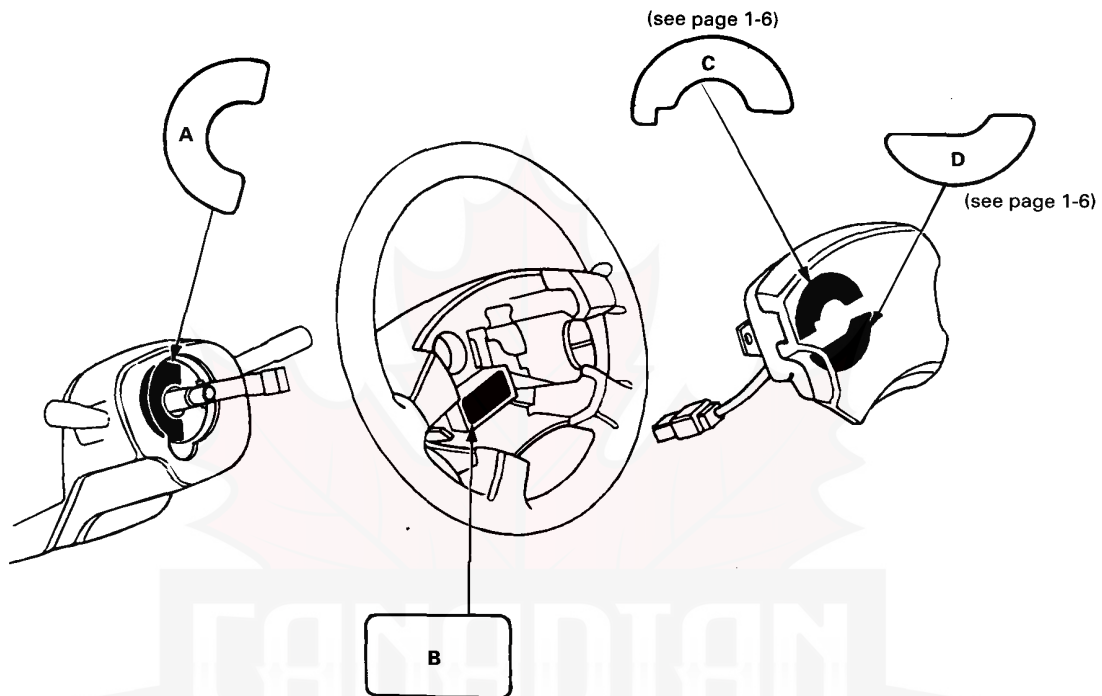

A: CABLE REEL CAUTION A

SRS

REFER TO SERVICE (SHOP) MANUAL FOR DETAILED INSTRUCTIONS.

POUR LES INSTRUCTIONS DETAILLÉES, SE REPORTER AU MANUEL DE REPARATIONS.

取扱い、保管はホンダサービスマニュアルを参照してください。

AUSFÜHRLICHE ANWEISUNGEN SIND DEM ZU ENTINEMEN.

RAAD PLEEG HET WERKPLAATSHANDBOEK VOOR NADERE AANWIJZINGEN.

(KM model)

NOTICE

IMPROPER STEERING WHEEL REMOVAL OR INSTALLATION CAN DAMAGE SRS COMPONENTS. FOLLOW SERVICE (SHOP) MANUAL INSTRUCTIONS CAREFULLY.

REMARQUE

UN RETRAIT OU UNE REPOSE INCORRECTS DU VOLANT RISQUENT D'ENDOMMAGER LES PIÈCES CONSTITUTIVES DU SRS. SUIVRE ATTENTIVEMENT LE MANUEL D'ENTRETIEN.

B: STEERING WHEEL WARNING

(Except KM model)

WARNING **SRS**

- REFER TO THE SHOP MANUAL.
- SE REPORTER AU MANUEL D'ATELIER.
- WERKSTATTHANDBUCH LESEN.
- LEES HET WERKPLAATSHANDBOEK.

(cont'd)

Warning/Caution Label Locations

(cont'd)

C: DRIVER MODULE DANGER (Except KM model)

- DANGER
EXPLOSIVE/FLAMMABLE
POISON
REFER TO THE SHOP MANUAL.
- DANGER
EXPLOSIF ET INFLAMMABLE
POISON
SE REPORTER AU MANUEL D'ATELIER.
- GEFAHR
EXPLOSIV/ENTZÜNDBAR
GIFT
WERKSTATTHANDBUCH LESEN.
- GEVAAR
EXPLOSIEGEVAAR/BRANDBAAR
GIFTIG
LEES HET WERKPLAATSHANDBOEK.

(KM model)

⚠ DANGER
EXPLOSIVE/FLAMMABLE
CONTACT WITH ACID, WATER, OR HEAVY METALS SUCH AS COPPER, LEAD, OR MERCURY, MAY PRODUCE HARMFUL AND IRRITATING GASES OR EXPLOSIVE COMPOUNDS. STORAGE TEMPERATURES MUST NOT EXCEED 200°F (100°C). FOR PROPER HANDLING, STORAGE AND DISPOSAL PROCEDURES REFER TO SERVICE (SHOP) MANUAL, SRS SUPPLEMENT.
POISON
CONTAINS POISONOUS SODIUM AZIDE AND POTASSIUM NITRATE.
FIRST AID
IF CONTENTS ARE SWALLOWED, INDUCE VOMITING. FOR EYE CONTACT, FLUSH EYES WITH WATER FOR 15 MINUTES. IF GASES (FROM ACID OR WATER CONTACT) ARE INHALED, SEEK FRESH AIR. IN EVERY CASE, GET PROMPT MEDICAL ATTENTION.
KEEP OUT OF REACH OF CHILDREN.

⚠ DANGER
EXPLOSIBLE/INFLAMMABLE
TOUT CONTACT AVEC L'ACIDE, L'EAU OU DES METAUX LOURDS COMME LE CUIVRE, LE PLOMB OU LE MERCURE RISQUE DE PRODUIRE DES GAZ NOCIFS ET IRRITANTS OU DES COMPOSES EXPLOSIFS. LES TEMPERATURES DE RANGEMENT NE DEVRONT PAS DEPASSER 200°F (100°C). POUR LES PROCEDURES DE MANIPULATION, DE RANGEMENT ET DE MISE AU REBUT, VOIR LE SUPPLEMENT SRS DU MANUEL D'ENTRETIEN.
POISON
RENFERME DE L'ACIDE DE SOUDE ET DU NITRATE DE POTASSIUM TOXIQUES.
PREMIERS SECOURS
SI LE CONTENU EST ABSORBE, INDUIRE UN VOMISSEMENT. EN CAS DE CONTACT AVEC LES YEUX, L'AVER A GRANDE EAU PENDANT UN QUART D'HEURE. EN CAS D'INHALATION DES GAZ (PAR CONTACT AVEC L'ACIDE OU L'EAU), ALLER A L'AIR FRAIS. DANS TOUS LES CAS, OBTENIR PROMPTEMENT DES SOINS MEDICAUX.
TENIR HORS DE PORTEE DES ENFANTS.

D: DRIVER MODULE WARNING (Except KM model)

- WARNING** **SRS**
- REFER TO THE SHOP MANUAL.
 - SE REPORTER AU MANUEL D'ATELIER.
 - WERKSTATTHANDBUCH LESEN.
 - LEES HET WERKPLAATSHANDBOEK.

(KM model)

- ⚠ WARNING**
THE AIRBAG INFLATOR IS EXPLOSIVE AND, IF ACCIDENTALLY DEPLOYED, CAN SERIOUSLY HURT OR KILL YOU.
- DO NOT USE ELECTRICAL TEST EQUIPEMENT OR PROBING DEVICES.
THEY CAN CAUSE ACCIDENTAL DEPLOYMENT.
 - NO SERVICEABLE PARTS INSIDE. DO NOT DISASSEMBLE.
 - PLACE AIRBAG UPRIGHT WHEN REMOVED.
 - FOLLOW SERVICE (SHOP) MANUAL INSTRUCTIONS CAREFULLY.

⚠ ATTENTION
LE GONFLEUR DE COUSSIN D'AIR EST EXPLOSIBLE ET S'LL SE DEPLOIE ACCIDENTELLEMENT, IL RISQUE DE PROVOQUER DES BLESSURES GRAVES OU DE TUER.

- NE PAS UTILISER DE MATERIEL D'ESSAI ELECTRIQUE NI DE SONDE.
ILS POURRAIENT PROVOQUER UN DEPLOIEMENT ACCIDENTEL DU COUSSIN D'AIR.
- IL N'Y A PAS DE PIECES REPARABLES A L'INTERIEUR.
NE PAS DEMONTER.
- QUAND ON RETIRE LE COUSSIN D'AIR, LE TENIR A LA VERTICALE.
- SUIVRE ATTENTIVEMENT LES INSTRUCTIONS DU MANUEL D'ENTRETIEN.

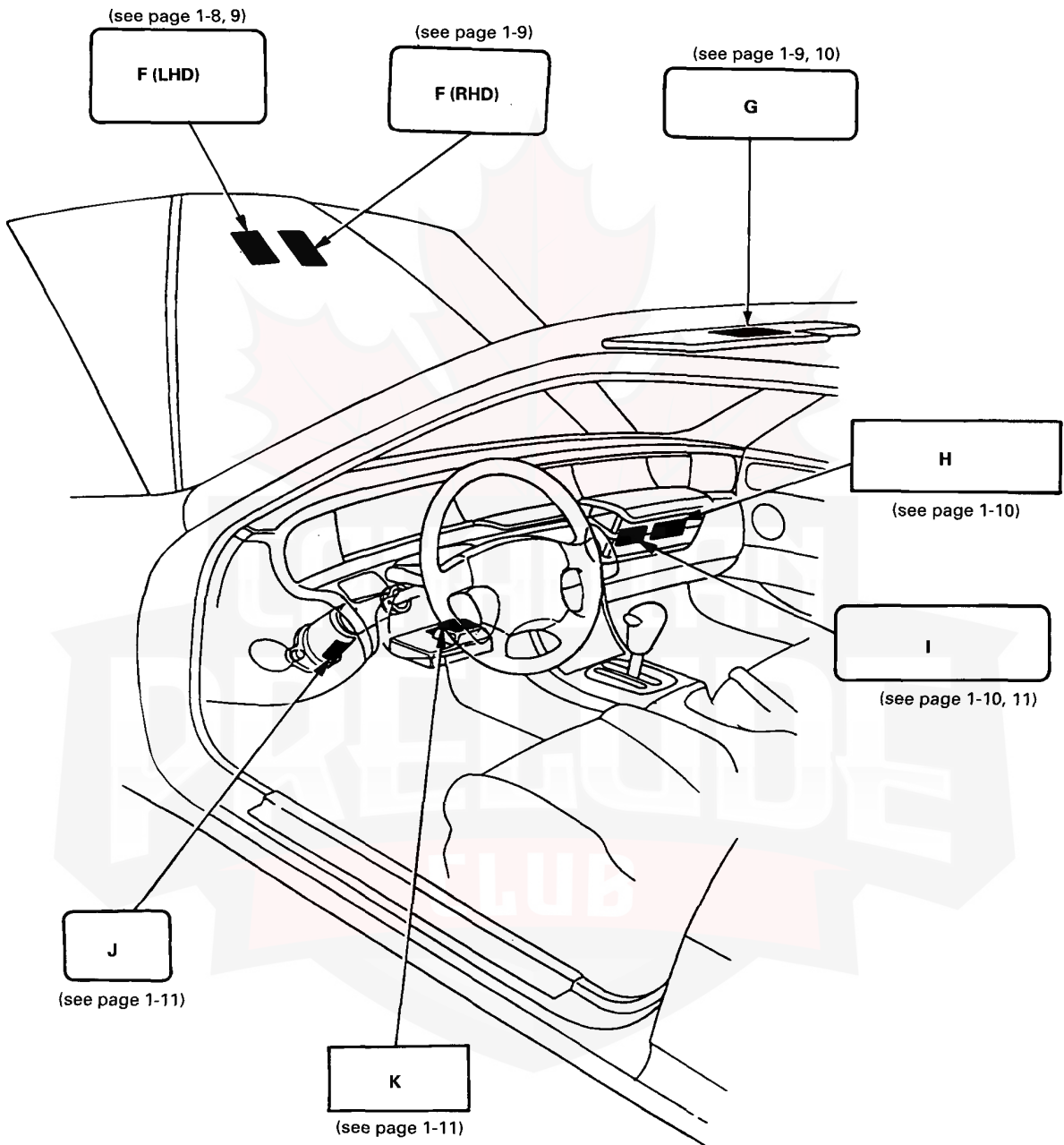

(cont'd)

Warning/Caution Label Locations

(cont'd)

E: BAM INFLATOR LABEL (European Model only)
Morton International, Inc. manufactured inflator:

AIR BAG GAS GENERATOR UT11600
MORTON INTERNATIONAL, INC.
OGDEN UT. USA
HERSTELLUNGSJAHR: 19XX
EINFÜHRER: HONDA DEUTSCHLAND
GMBH/OFFENBACH
BAM PT.-0388

DER GASGENERATOR DARF NUR FÜR INSASSEN-
RÜCKHALTESYSTEME MIT LUFTSACK IN KRAFTFAHR-
ZEUGE MONTIERT WERDEN.
DIE MONTAGE UND DEMONTAGE DES GASGENERA-
TORS DARF NUR VON DAFÜR GESCHULTEM PERSONAL
VORGENOMMEN WERDEN.

CAUTION CONTAINS FLAMMABLE SOLIDS US DOT-E-8214	THE GAS GENERATOR SHOULD ONLY BE INSTALLED IN VEHICLES EQUIPPED WITH THE AIRBAG SYSTEM. THE GAS GENERATOR IS TO BE INSTALLED AND/OR DISASSEMBLED ONLY BY TRAINED PERSONNEL.
--	---

ATTENTION CONTENT DE SOLIDES FLAMMABLES US DOT-E-8214	LE GENERATEUR DE GAZ NE PEUT ETRE INSTALLE QUE SUR DES VEHICULES EQUIPES D'UN SYSTEME AIRBAG. LE MONTAGE ET LE DEMONTAGE DU GENERATEUR DE GAZ NE PEUT ETRE EFFECTUE QUE PAR UN PERSONNEL QUALIFIE.
---	--

NIPPON KOKI manufactured inflator

AIRBAG GAS GENERATOR NK8
NIPPON KOKI, SHIRAKAWA JAPAN
HERSTELLUNGSJAHR: 19XX
EINFÜHRER: HONDA DEUTSCHLAND
GMBH/OFFENBACH
BAM PT.-0379

DER GASGENERATOR DART NUR FÜR INSASSEN-
RÜCKHALTESYSTEME MIT LUFTSACK IN KRAFTFAHR-
ZEUGE MONTIERT WERDEN.
DIE MONTAGE UND DEMONTAGE DES GASGENERA-
TORS DARF NUR VON DAFÜR GESCHULTEM PERSONAL
VORGENOMMEN WERDEN.

CAUTION CONTAINS FLAMMABLE SOLIDS	THE GAS GENERATOR SHOULD ONLY BE INSTALLED IN VEHICLES EQUIPPED WITH THE AIRBAG SYSTEM. THE GAS GENERATOR IS TO BE INSTALLED AND/OR DISASSEMBLED ONLY BY TRAINED PERSONNEL.
---	---

ATTENTION CONTENT DE SOLIDES FLAMMABLES	LE GENERATEUR DE GAZ NE PEUT ETRE INSTALLE QUE SUR DES VEHICULES EQUIPES D'UN SYSTEME AIRBAG. LE MONTAGE ET LE DEMONTAGE DU GENERATEUR DE GAZ NE PEUT ETRE EFFECTUE QUE PAR UN PERSONNEL QUALIFIE.
--	--

F: SRS WARNING
(KS model)

WARNING **SRS**
THIS VEHICLE IS EQUIPPED WITH AN AIRBAG SYSTEM
AS A SUPPLEMENTAL RESTRAINT SYSTEM (SRS).
ALL S.R.S. ELECTRICAL WIRING AND CONNECTORS ARE
COLORED YELLOW.
DO NOT USE ELECTRICAL TEST EQUIPMENT ON THESE
CIRCUITS.
TAMPERING WITH OR DISCONNECTING THE S.R.S.
WIRING COULD RESULT IN ACCIDENTAL FIRING OF THE
INFLATOR OR MAKE THE SYSTEM INOPERATIVE,
WHICH MAY RESULT IN SERIOUS INJURY.

VARNING **SRS**
DETTA FORDON HAR EN LUFTKUDDE FÖR FÖRARSÄTET
SOM ETT KOMPLETTERANDE SKYDDSSYSTEM (SRS).
SAMTLIGA ELLEDNINGAR OCH KONTAKTER I SRS-
SYSTEMET ÄR GULFÄRGÅDE. ANVÄND INTE ELEKTRISK
PROVUTRUSTNING FÖR DESSA KRETSAR. OM DU
ÄNDRAR ELLER LOSSAR EN SRS-LEDNING KAN DET
RESULTERA I EN OAVSIKTLIG UTLÖSNING AV
TRYCKPUMPEN ELLER GÖRA ATT SYSTEMET SLUTAR
FUNGERA. DÅ KAN EN ALLVARLIG OLYCKA UPPSTÅ.

VAROITUS **SRS**
TÄSSÄ AUTOSSA ON YLIMÄÄRÄISENÄ
TUKIJÄRJESTELMÄNÄ AJAJAN ILMATYNY. (SRS)
KAIKKI SRS-SÄHKÖJOHDOT JA-LIITTIMET OVAT
KELTAISET.
ÄLÄ KÄYTÄ SÄHKÖKOELAITTEITA NÄISSÄ
VIRTAPIIREISÄÄ. SRS-JOHTOJEN TUKKEAMINEN TAI
IRROTTAAMINEN SAATTAU SYTYTTÄÄ VAHINGOSSA
PUMPUN TAI TEHDÄ JÄRJESTELMÄN
KÄYTTÖKELVOTTOMAKSI.
TÄSTÄ TAAS SAATTAU AIHEUTUA VAKAVIA
VAURIOITA.

(KM model)

SUPPLEMENTAL RESTRAINT SYSTEM (SRS)
THIS VEHICLE IS EQUIPPED WITH A DRIVER AND FRONT
SEAT PASSENGER AIRBAG.
ALL SRS ELECTRICAL WIRING AND CONNECTORS ARE
COLORED YELLOW.
TAMPERING WITH, DISCONNECTING OR USING
ELECTRICAL TEST EQUIPMENT ON THE SRS WIRING
CAN MAKE THE SYSTEM INOPERATIVE OR CAUSE
ACCIDENTAL FIRING OF THE INFLATOR.

⚠ WARNING
THE AIRBAG INFLATOR IS EXPLOSIVE AND, IF
ACCIDENTALLY DEPLOYED, CAN SERIOUSLY HURT YOU.
FOLLOW SERVICE (SHOP) MANUAL INSTRUCTIONS
CAREFULLY.



F: SRS WARNING
(Except KS, KM models)

WARNING **SRS**

THIS VEHICLE IS EQUIPPED WITH A DRIVER AIRBAG AS A SUPPLEMENTAL RESTRAINT SYSTEM. (SRS)
ALL S.R.S. ELECTRICAL WIRING AND CONNECTORS ARE COLORED YELLOW.

DO NOT USE ELECTRICAL TEST EQUIPMENT ON THESE CIRCUITS.

TAMPERING WITH OR DISCONNECTING THE S.R.S. WIRING COULD RESULT IN ACCIDENTAL FIRING OF THE INFLATOR OR MAKE THE SYSTEM INOPERATIVE, WHICH MAY RESULT IN SERIOUS INJURY.

ATTENTION **SRS**

CE VEHICULE EST EQUIPE D'UN COUSSIN D'AIR DU COTE CONDUCTEUR QUI CONSTITUE UN SYSTEME DE RETENUE COMPLEMENTAIRE (S.R.S.).

TOUS LES FILS ET CONNECTEURS ELECTRIQUES DU SYSTEME DE RETENUE COMPLEMENTAIRE (S.R.S.) SONT DE COULEUR JAUNE. N'UTILISEZ PAS UN EQUIPEMENT D'ESSAIS ELECTRIQUES SUR CES CIRCUITS. NE TOUCHEZ PAS ET NE DEBRANCHEZ PAS LES FILS DU SYSTEME S.R.S. CAR CELA POURRAIT DE TRADUIRE PAR LE DECLENCHEMENT ACCIDENTEL DU GONFLEUR OU RENDRE LE SYSTEME INOPERANT ET VOUS EXPOSER AINSI A DE GRAVES BLESSURES.

WARNUNG **SRS**

DIESES FAHRZEUG IST MIT EINEM FAHRER-AIRBAG (SRS) ALS ZUSÄTZLICHEM RÜCKHALTESYSTEM AUSGERÜSTET.

ALLE ELEKTRISCHEN KABEL, SOWIE DIE ZUGEHÖRIGEN STECKVERBINDER DES S.R.S.-SYSTEMS SIND IN GELBER FARBE AUSGEFÜHRT. KEINE ELEKTRISCHEN PRÜFGERÄTE AN DIE S.R.S.-VERKABELUNG ANSCHLIEßEN. VERÄNDERN ODER UNTERBRECHEN DER S.R.S.-VERKABELUNG KANN UNKONTROLLIERTES ZÜNDEN DES GASGENERATORS AUSLÖSEN. ODER DAS SYSTEM AUßER FUNKTION SETZEN WAS ZU ERNSTHAFTEN VERLETZUNGEN FÜHREN KANN.

WAARSCHUWING **SRS**

DIT VOERTUIG IS UITGERUST MET EEN LUCHTKUSSEN AAN DE BESTUURDERSKANT ALS EXTRA BESCHERMING (S.R.S.).

ALLE ELEKTRISCHE LEIDINGEN EN AANSLUITINGEN VAN DE S.R.S. ZIJN GEEL GEKLEURD. GEBRUIK GEEN ELEKTRISCHE TESTAPPARATUUR VOOR DEZE CIRCUITS. KNOEIEEN MET OF LOSKOPPELEN VAN DE S.R.S. LEIDINGEN KAN LEIDEN TOT BRAND IN DE VULINRICHTING OF TOT UITSCHAKELEN VAN HET SYSTEEM DIT KAN TOT ERNSTIGE ONGELUKKEN LEIDEN.

G: DRIVER INFORMATION
(Except KS, KE, KM models)

SRS ALWAYS WEAR YOUR SEAT BELT

- THIS CAR IS EQUIPPED WITH A DRIVER AIRBAG AND FRONT SEAT PASSENGER AIRBAG AS A SUPPLEMENTAL RESTRAINT SYSTEM (S.R.S.).
- IT IS DESIGNED TO SUPPLEMENT THE SEAT BELT.
- IF YOUR SRS INDICATOR LIGHTS WHILE DRIVING SEE YOUR AUTHORIZED HONDA DEALER.

SRS ATTACHEZ TOUJOURS VOTRE CEINTURE

- CE VEHICULE EST EQUIPE D'UN COUSSIN D'AIR POUR LE PASSAGER AVANT, QUI CONSTITUE UN SYSTEME DE RETENUE COMPLEMENTAIRE (S.R.S.).
- CE COUSSIN D'AIR COMPLETE LA FONCTION DE LA CEINTURE DE SECURITE.
- SI LE TEMOIN SRS S'ALLUME PENDANT LA CONDUITE, ADRESSEZ-VOUS A VOTRE CONCESSIONNAIRE HONDA OFFICIEL.

SRS SICHERHEITSGURTE BEI JEDER FAHRT ANLEGEN

- DIESES FAHRZEUG BESITZT JE EINEN AIRBAG FÜR FAHRER UND BEIFAHREER ALS ZUSÄTZLICHES RÜCKHALTESYSTEM (S.R.S.).
- DAS RÜCKHALTESYSTEM IST EINE ERGÄNZUNG ZUM SICHERHEITSGURT.
- SOLLTE WAHREND DER FAHRT DIE SRS-KONTROLLEUCHTE AUFLEUCHTEN SUCHEN SIE BITTE UMGEHEND EINEN HONDA-HÄNDLER SUF.

SRS DRAAG ALTIJD UW VEILIGHEIDSGORDEL

- DIT VOERTUIG IS UITGERUST MET AIRBAG (SRS) AAN BESTUURDERSZIJDE EN PASSAGIERSZIJDE VOOR EXTRA VEILIGHEID.
- ONTWORPEN ALS EXTRA BESCHERMING NAAST DE VEILIGHEIDSGORDELS.
- ALS HET SRS-WAARSCHUWINGSLAMPJE GAAT BRANDEN ONDER HET RIJDEN, NEEM DAN CONTACT OP MET EEN HONDA DEALER.

(cont'd)

Warning/Caution Label Locations

(cont'd)

(KE, KM model)

SRS ALWAYS WEAR YOUR SEAT BELT

- THIS CAR IS EQUIPPED WITH A DRIVER AIRBAG AND FRONT SEAT PASSENGER AIRBAG AS A SUPPLEMENTAL RESTRAINT SYSTEM (S.R.S.).
- IT IS DESIGNED TO SUPPLEMENT THE SEAT BELT.
- IF YOUR SRS INDICATOR LIGHTS WHILE DRIVING SEE YOUR AUTHORIZED HONDA DEALER.

(KS model)

SRS ALWAYS WEAR YOUR SEAT BELT

- THIS CAR IS EQUIPPED WITH A DRIVER AIRBAG AND A FRONT SEAT PASSENGER AIRBAG AS A SUPPLEMENTAL RESTRAINT SYSTEM (S.R.S.).
- IT IS DESIGNED TO SUPPLEMENT THE SEAT BELT.
- IF YOUR SRS INDICATOR LIGHTS WHILE DRIVING SEE YOUR AUTHORIZED HONDA DEALER.

SRS ANVÄND ALLTID BILBÄLTET

- DETTA FORDON HÄR FÖRSETT MED EN LUFTKUDDE FÖR FÖRARSÄTET OCH EN LUFTKUDDE FÖR PASSAGERARSÄTET FRAM SOM ETT KOMPLEMENTERANDE SKYDDSSYSTEM (S.R.S.).
- DET ÄR ÄMNAT ATT KOMPLEMENTERA BILBÄLTET.
- OM SRS-INDIKATORN TÄNDS UNDER KÖRNING SKALL DU KONTAKTA EN AUKTORISERAD HONDA-ATERFÖRSÄLJARE.

SRS KÄYTÄ AINA TURVAVÖITÄ

- TÄMÄ AUTO ON VARUSTETTU AJAJAN ILMATYNYLLÄ JA ETUMATKUSTAJAN ILMATYNYLLÄ JOTKA TOIMIVAT YLMÄÄRÄISENÄ TUKIJÄRJESTELMÄNÄ. (S.R.S.).
- SE ON SUUNNITELTU TÄYDENTÄMÄÄN TURVAVYÖTÄ.
- JOS SRS-MERKKIVALO SYTTYY AJON AIKANA, OTTAKAA YHTEYS VALTUUTETTUUN HONDA-MYYJÄÄN.

H: BAM INFLATOR LABEL

AIRBAG GAS GENERATOR UT 11873
MORTON INTERNATIONAL, INC. OGDEN, USA
HERSTELLUNGS: (JAHR)
EINFÜHRER: HONDA DEUTSCHLAND
GMBH 6050 OFFENBACH
BAM PT.-0437

DER GASGENERATOR DARF NUR FÜR INSASSEN-RÜCKHALTESYSTEME MIT LUFTSACK IN KRAFTFAHRZEUGE MONTIERT WERDEN.
DIE MONTAGE UND DEMONTAGE DES GASGENERATORS DARF NUR VON DAFÜR GESCHULTEM PERSONAL VORGENOMMEN WERDEN.

CAUTION
CONTAINS
FLAMMABLE
SOLIDS

THE GAS GENERATOR SHOULD ONLY BE INSTALLED IN VEHICLES EQUIPPED WITH THE AIRBAG SYSTEM. THE GAS GENERATOR IS TO BE INSTALLED AND/OR DISASSEMBLED ONLY BY TRAINED PERSONNEL.

ATTENTION
CONTENT
DE
SOLIDES
FLAMMABLES

LE GENERATEUR DE GAZ NE PEUT ETRE INSTALLE QUE SUR DES VEHICULES EQUIPES D'UN SYSTEME AIRBAG LE MONTAGE ET LE DEMONTAGE DU GENERATEUR DE GAZ NE PEUT ETRE EFFECTUE QUE PAR UN PERSONNEL QUALIFIE.

I: FRONT SEAT PASSENGER AIRBAG MODULE
DANGER (Except KM model)

- **DANGER**
EXPLOSIVE/FLAMMABLE
POISON
- **WARNING**
REFER TO THE SHOP MANUAL.
- **DANGER**
EXPLOSIF ET INFLAMMABLE
POISON
- **ATTENTION**
SE REPORTER AU MANUEL D'ATELIER.
- **GEFAHR**
EXPLOSIV/ENTZÜNDBAR
GIFT
- **WARNUNG**
WERKSTATTHANDBUCH LESEN.
- **GEVAAR**
EXPLOSIEGEVAAR/BRANDBAAR
GIFTIG
- **WAARSCHUWING**
LEES HET WERKPLAATSHANDBOEK.

SRS



(KM model)

⚠ DANGER
EXPLOSIVE/FLAMMABLE
 CONTACT WITH ACID, WATER, OR HEAVY METALS SUCH AS COPPER, LEAD OR MERCURY MAY PRODUCE HARMFUL AND IRRITATING GASES OR EXPLOSIVE COMPOUNDS. STORAGE TEMPERATURES MUST NOT EXCEED 200°F (100°C). FOR PROPER HANDLING, STORAGE AND DISPOSAL PROCEDURES REFER TO SERVICE (SHOP) MANUAL, SRS SUPPLEMENT.

POISON
 CONTAINS POISONOUS SODIUM AZIDE AND POTASSIUM NITRATE.

FIRST AID
 IF CONTENTS ARE SWALLOWED, INDUCE VOMITING. FOR EYE CONTACT, FLUSH EYES WITH WATER FOR 15 MINUTES. IF GASES (FROM ACID OR WATER CONTACT) ARE INHALED, SEEK FRESH AIR, IN EVERY CASE, GET PROMPT MEDICAL ATTENTION.
 KEEP OUT OF REACH OF CHILDREN.

⚠ WARNING
 THE AIRBAG INFLATOR IS EXPLOSIVE AND, IF ACCIDENTALLY DEPLOYED, CAN SERIOUSLY HURT OR KILL YOU.

- DO NOT USE ELECTRICAL TEST EQUIPEMENT OR PROBING DEVICES. THEY CAN CAUSE ACCIDENTAL DEPLOYMENT.
- NO SERVICEABLE PARTS INSIDE. DO NOT DISASSEMBLE.
- PLACE AIRBAG UPRIGHT WHEN REMOVED.
- FOLLOW SERVICE (SHOP) MANUAL INSTRUCTIONS CAREFULLY.

⚠ DANGER
EXPLOSIBLE/INFLAMMABLE
 TOUT CONTACT AVEC L'ACIDE, L'EAU OU DES METAUX LOURDS COMME LE CUIVRE, LE PLOMB OU LE MERCURE RISQUE DE PRODUIRE DES GAZ NOCIFS ET IRRITANTS OU DES COMPOSES EXPLOSIFS. LES TEMPERATURES DE RANGEMENT NE DEVRONT PAS DEPASSER 200°F (100°C). POUR LES PROCEDURES DE MANIPULATION, DE RANGEMENT ET DE MISE AU REBUT, VOIR LE SUPPLEMENT SRS DU MANUEL D'ENTRETIEN.

POISON
 RENFERME DE L'ACIDE DE SOUDE ET DU NITRATE DE POTASSIUM TOXIQUES.

PREMIERS SECOURS
 SI LE CONTENU EST ABSORBE, INDIURE UN VOMISSEMENT. EN CAS DE CONTACT AVEC LES YEUX, LAVER A GRANDE EAU PENDANT UN QUART D'HEURE. EN CAS D'INHALATION DES GAZ (PAR CONTACT AVEC L'ACIDE OU L'EAU). ALLER A L'AIR FRAIS. DANS TOUS LE CAS, OBETENIR PROMPTEMENT DES SOINS MEDICAUX.
 TENIR HORS DE PORTEE DES ENFANTS.

⚠ ATTENTION
 LE GONFLEUR DE COUSSIN D'AIR EST EXPLOSIBLE ET S'LL SE DEPLOIE ACCIDENTELLEMENT, IL RISQUE DE PROVOQUER DES BLESSURES GRAVES OU DE TUER.

- NE PAS UTILISER DE MATERIEL D'ESSAI ELECTRIQUE NI DE SONDE. ILS POURRAIENT PROVOQUER UN DEPLOIEMENT ACCIDENTEL DU COUSSIN D'AIR.
- IL N'Y A PAS DE PIECES REPARABLES A L'INTERIEUR. NE PAS DEMONTER.
- QUAND ON RETIRE LE COUSSIN D'AIR, LE TENIR A LA VERTICALE.
- SUIVRE ATTENTIVEMENT LES INSTRUCTIONS DU MANUEL D'ENTRETIEN.

J: STEERING COLUMN NOTICE

NOTICE
 TO PREVENT SRS DAMAGE, REMOVE STEERING WHEEL BEFORE REMOVING STEERING SHAFT CONNECTING BOLT.

REMARQUE
 POUR EVITER TOUT DOMMAGE DU SRS, RETIRER LE VOLANT AVANT DE RETIRER LE BOULON DE RECCORDMENT DE L'ARBRE DE DIRECTION.

K: SRS MONITOR NOTICE

NOTICE

- NO SERVICEABLE PARTS INSIDE.
- REFER TO SERVICE (SHOP) MANUAL FOR DETAILED INSTRUCTIONS.

お願い

- 分解しないでください。
- 取扱い、保管はホンダ サービス マニュアルを参照してください。

REMARQUE

- AUCUNE PIECE REPARABLE A L'INTERIEUR.
- POUR LES INSTRUCTIONS DETAILL'EES, SE REPORTER AU MANUEL DE REPARATIONS.

LET OP

- GEEN ONDERDELEN BINNEN DEZE UNIT WAARAAN WERKZAAMHEDEN KUNNEN WORDEN VERRICHT.
- RAADPLEEG HET WERKPLAATSHANDBOEX VOOR NADERE AANWIJZINGEN.

ACHTUNG

- DIE INNENTILE BEDÜRFEN KEINER WARTUNG.
- AUSFÜHRLICHE ANWEISUNGEN SIND DEM WERKSTATTHANDBUCH ZU ENTNEHMEN.

(cont'd)

Warning/Caution Label Locations

(cont'd)

SRS Airbag System Type II:

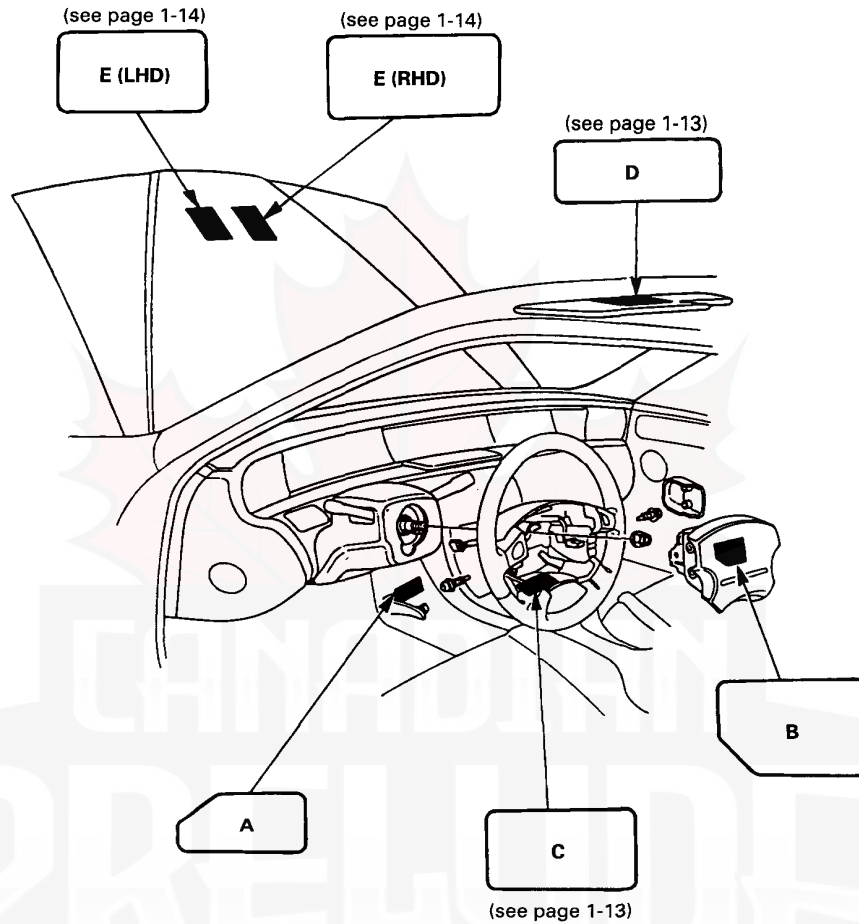

A: MAINTENANCE LID CAUTION

注意

SRS メンテナンスは、イグニッション スイッチを切ってから行うこと。

SRS

CAUTION
BEFORE MAINTENANCE, SWITCH OFF THE IGNITION.

ATTENTION
AVANT TOUT ENTRETIEN, COUPER LE CONTACT.

ACHTUNG
VOR WARTUNG ZÜNDUNG AUSSCHALTEN.

LET OP
ZET HET KONTAKTSLOT AF ALVORENS MET HET ONDERHOUD TE BEGINNEN.

B: MONITOR NOTICE

NOTICE

• REFER TO SERVICE (SHOP) MANUAL FOR DETAILED INSTRUCTIONS.

REMARQUE

• POUR LES INSTRUCTIONS DETAILLÉES, SE REPORTER AU MANUEL DE REPARATIONS.

LET OP

• RAADPLEEG HET WERKPLAATSHANDBOEK VOOR NADERE AANWIJZINGEN.

ACHTUNG

• AUSFÜHRLICHE ANWEISUNGEN SIND DEM WERKSTATTHANDBUCH ZU ENTNEHMEN.

SRS



C: BODY COVER CAUTION

注意 CAUTION ACHTUNG **SRS**

- SRSメンテナンス時はサービス マニュアルを参照すること。
- REFER TO THE SERVICE (SHOP) MANUAL.
- SE REPORTER AU MANUEL D'ATELIER.
- WERKSTATTHANDBUCH LESEN.
- LEES HET WERKPLAATSHANDBOEK.

D: DRIVER INFORMATION (Except KE, KQ, KS models)

SRS ALWAYS WEAR YOUR SEAT BELT

- THIS CAR IS EQUIPPED WITH A DRIVER AIRBAG AS A SUPPLEMENTAL RESTRAINT SYSTEM (S.R.S.).
- IT IS DESIGNED TO SUPPLEMENT THE SEAT BELT.
- IF YOUR SRS INDICATOR LIGHTS WHILE DRIVING, SEE YOUR AUTHORIZED HONDA DEALER.

SRS ATTACHEZ TOUJOURS VOTRE CEINTURE

- CE VEHICULE EST EQUIPE D'UN COUSSIN D'AIR POUR LE CONDUCTEUR QUI CONSTITUE UN SYSTEME DE RETENUE COMPLEMENTAIRE (S.R.S.).
- CE COUSSIN D'AIR COMPLETE LA FONCTION DE LA CEINTURE DE SECURITE.
- SI LE TMOIN SRS S'ALLUME PENDANT LA CONDUITE, ADRESSEZ-VOUS A VOTRE CONCESSIONNAIRE HONDA OFFICIEL.

SRS SICHERHEITSGURTE BEI JEDER FAHRT ANLEGEN

- DIESES FAHRZEUG BESITZT EINEN FAHRER-AIRBAG ALS ZUSÄTZLICHES RÜCKHALTESYSTEM (S.R.S.).
- ES IST EINE ERGÄNZUNG ZUM SICHERHEITSGURT.
- WENN DIE SRS-KONTROLLEUCHE WÄHREND DER FAHRT AUFLEUCHTET, UMGEHEND FINEN HONDA HÄNDLER AUFZUSUCHEN.

SRS DRAAG ALTIJD UW VEILIGHEIDSGORDEL

- DIT VOERTUIG IS UITGERUST MET EEN LUCHTKUSSEN AAN DE BESTUURDESKANT ALTS EXTRA BESCHERMING (S.R.S.).
- DIT IS ONTWERPEN ALS EXTRA BESCHERMING BIJ DE VEILIGHEIDSGORDEL.
- ALS HEL SRS-WAARSCHUWINGSLAMPJE GAAT BRANDEN ONDER HET RIJDEN. NEEM DAN KONTAKT OP MET EEN HONDA DEALER.

(KE, KQ models)

SRS ALWAYS WEAR YOUR SEAT BELT

- THIS CAR IS EQUIPPED WITH A DRIVER AIRBAG AS A SUPPLEMENTAL RESTRAINT SYSTEM (SRS).
- IT IS DESIGNED TO SUPPLEMENT THE SEAT BELT.
- IF YOUR SRS INDICATOR LIGHTS WHILE DRIVING SEE YOUR AUTHORIZED HONDA DEALER.

(KS model)

SRS ALWAYS WEAR YOUR SEAT BELT

- THIS CAR IS EQUIPPED WITH A DRIVER AIRBAG AS A SUPPLEMENTAL RESTRAINT SYSTEM (S.R.S.).
- IT IS DESIGNED TO SUPPLEMENT THE SEAT BELT.
- IF YOUR SRS INDICATOR LIGHTS WHILE DRIVING SEE YOUR AUTHORIZED HONDA DEALER.

SRS ANVÄND ALLTID BILBÄLTET

- DETTA FORDON HÄR EN LUFTKUDDE FÖR FÖRARSÄTET SOM ETT KOMPLEMENTERANDE SKYDDSSYSTEM (S.R.S.).
- DET ÄR ÄMNAT ATT KOMPLEMENTERA BILBÄLTET.
- OM SRS-INDIKATORN TÄNDS UNDER KÖRNING SKALL DU KONTAKTA EN AUKTORISERAD HONDA-ATERFÖRSÄLJARE.

SRS KÄYTÄ AINA TURVAVÖITÄ

- TÄMÄ AUTO ON VARUSTETTU AJAJAN ILMATYNYLLÄ JOKA ON YLIMÄÄRÄINEN TUKIJÄRJESTELMÄNÄ. (S.R.S.).
- SE ON SUUNNITELTU TÄYDENTÄMÄÄN TURVAVYÖTÄ.
- JOS SRS-MERKKIVALO SYTTY AJOIN AIKANA, OTTAKAA YHTEYS VALTUUTETTUUN HONDA-MYYJÄÄN.

(cont'd)

Warning/Caution Label Locations

(cont'd)

E: SRS WARNING (Except KS model)

WARNING **SRS**

THIS VEHICLE IS EQUIPPED WITH A DRIVER AIRBAG AS A SUPPLEMENTAL RESTRAINT SYSTEM. (SRS)
ALL S.R.S. ELECTRICAL WIRING AND CONNECTORS ARE COLORED YELLOW.
DO NOT USE ELECTRICAL TEST EQUIPMENT ON THESE CIRCUITS.
TAMPERING WITH OR DISCONNECTING THE S.R.S. WIRING COULD RESULT IN ACCIDENTAL FIRING OF THE INFLATOR OR MAKE THE SYSTEM INOPERATIVE, WHICH MAY RESULT IN SERIOUS INJURY.

ATTENTION **SRS**

CE VEHICULE EST EQUIPE D'UN COUSSIN D'AIR DU COTE CONDUCTEUR QUI CONSTITUE UN SYSTEME DE RETENUE COMPLEMENTAIRE (S.R.S.).
TOUS LES FILS ET CONNECTEURS ELECTRIQUES DU SYSTEME DE RETENUE COMPLEMENTAIRE (S.R.S.) SONT DE COULEUR JAUNE. N'UTILISEZ PAS UN EQUIPEMENT D'ESSAIS ELECTRIQUES SUR CES CIRCUITS. NE TOUCHEZ PAS ET NE DEBRANCHEZ PAS LES FILS DU SYSTEME S.R.S. CAR CECI POURRAIT DE TRADUIRE PAR LE DECLENCHEMENT ACCIDENTEL DU GONFLEUR OU RENDRE LE SYSTEME INOPERANT ET VOUS EXPOSER AINSI A DE GRAVES BLESSURES.

WARNUNG **SRS**

DIESES FAHRZEUG IST MIT EINEM FAHRER-AIRBAG (SRS) ALS ZUSÄTZLICHEM RÜCKHALTESYSTEM AUSGERÜSTET.
ALLE ELEKTRISCHEN KABEL, SOWIE DIE ZUGEHÖRIGEN STECKVERBINDER DES S.R.S.-SYSTEMS SIND IN GELBER FARBE AUSGEFÜHRT. KEINE ELEKTRISCHEN PRÜFGERÄTE AN DIE S.R.S.-VERKABELUNG ANSCHLIEßEN, VERÄNDERN ODER UNTERBRECHEN DER S.R.S.-VERKABELUNG KANN UNKONTROLLIERTES ZÜNDEN DES GASGENERATORS AUSLÖSEN.
ODER DAS SYSTEM AUßER FUNKTION SETZEN WAS ZU ERNSTHAFTEN VERLETZUNGEN FÜHREN KANN.

WAARSCHUWING **SRS**

DIT VOERTUIG IS UITGERUST MET EEN LUCHTKUSSEN AAN DE BESTUURDERSKANT ALS EXTRA BESCHERMING (S.R.S.).
ALLE ELEKTRISCHE LEIDINGEN EN AANSLUITINGEN VAN DE S.R.S. ZIJN GEEL GEKLEURD. GEBRUIK GEEN ELEKTRISCHE TESTAPPARATUUR VOOR DEZE CIRCUITS.
KNOEIEN MET OF LOSKOPPELEN VAN DE S.R.S. LEIDINGEN KAN LEIDEN TOT BRAND IN DE VULINRICHTING OF TOT UITSCHAKELLEN VAN HET SYSTEEM DIT KAN TOT ERNSTIGE ONGELUKKEN LEIDEN.

(KS model)

WARNING **SRS**

THIS VEHICLE IS EQUIPPED WITH AN AIRBAG SYSTEM AS A SUPPLEMENTAL RESTRAINT SYSTEM (SRS).
ALL S.R.S. ELECTRICAL WIRING AND CONNECTORS ARE COLORED YELLOW.
DO NOT USE ELECTRICAL TEST EQUIPMENT ON THESE CIRCUITS.
TAMPERING WITH OR DISCONNECTING THE S.R.S. WIRING COULD RESULT IN ACCIDENTAL FIRING OF THE INFLATOR OR MAKE THE SYSTEM INOPERATIVE, WHICH MAY RESULT IN SERIOUS INJURY.

VARNING **SRS**

DETTA FORDON HAR EN LUFTKUDDE FÖR FÖRARSÄTET SOM ETT KOMPLETTERANDE SKYDDSSYSTEM (SRS).
SAMTLIGA ELLEDNINGAR OCH KONTAKTER I SRS-SYSTEMET ÄR GULFÄRGÅDE. ANVÄND INTE ELEKTRISK PROVUTRUSTNING FÖR DESSA KRETSAR. OM DU ÄNDRAR ELLER LOSSAR EN SRS-LEDNING KAN DET RESULTERA I EN OAVSIKTIG UTLÖSNING AV TRYCKPUMPEN ELLER GÖRA ATT SYSTEMET SLUTAR FUNGERA. DÅ KAN EN ALLVARLIG OLYCKA UPPSTÅ.

VAROITUS **SRS**

TÄSSÄ AUTOSSA ON YLIMÄÄRÄISENÄ TUKIJÄRJESTELMÄNÄ AJAJAN ILMATYYNY. (SRS)
KAIKKI SRS-SÄHKÖJOHDOT JA-LIITTIMET OVAT Keltaiset.
ÄLÄ KÄYTÄ SÄHKÖKOELAITTEITA NÄISSÄ VIRTAPIIREISÄÄ. SRS-JOHTOJEN TUKKEAMINEN TAI IRROTTAMINEN SAATTAA SYTYTTÄÄ VAHINGOSSA PUMPUN TAI TEHDÄ JÄRJESTELMÄN KÄYTTÖKELVOTTOMAKSI.
TÄSTÄ TAAS SAATTAA AIHEUTUA VAKAVIA VAURIOITA.



Special Tools

Individual tool lists are located at the front of each section.



Specifications

Standards and Service Limits	3-2
Design Specifications.....	3-17
Body Specifications.....	3-22

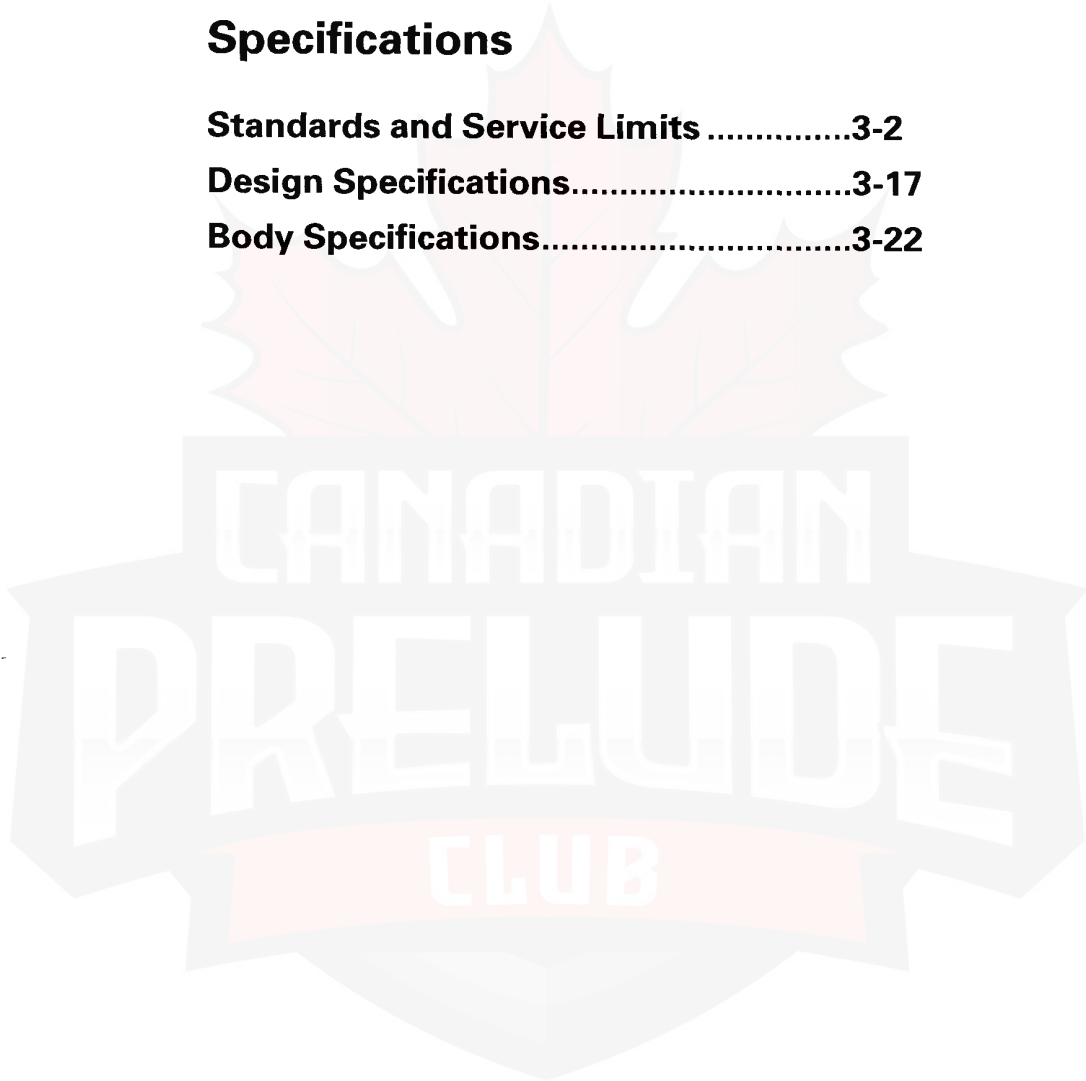

Standards and Service Limits

Cylinder Head/Valve Train — Section 6 (F20A4, F22A1, F22A2 engines)

		MEASUREMENT		STANDARD (NEW)		SERVICE LIMIT	
Compression	250 min ⁻¹ (rpm) and wide open throttle kPa (kg/cm ² , psi)	Nominal Minimum Maximum variation		1,250 (12.5, 178) 950 (9.5, 135) 200 (2.0, 28)			
Cylinder head	Warpage Height			— 99.95—100.05 (3.935—3.939)			0.05 (0.002) —
Camshaft	End play Camshaft-to-holder oil clearance Runout Cam lobe Height	F20A4, F22A2 engines F22A1 engine	IN EX IN EX	0.05—0.15 (0.002—0.006) 0.050—0.089 (0.0020—0.0035) 0.03 (0.001) max. 38.741 (1.5252) 38.972 (1.5343) 38.526 (1.5168) 38.778 (1.5267)			0.5 (0.02) 0.15 (0.006) 0.04 (0.002) — — — —
Valve	Valve clearance Valve stem O.D. Stem-to-guide clearance		IN EX IN EX IN EX	0.23—0.28 (0.009—0.011) 0.27—0.32 (0.011—0.013) 5.485—5.495 (0.2159—0.2163) 5.450—5.460 (0.2146—0.2150) 0.020—0.045 (0.0008—0.0018) 0.055—0.080 (0.0022—0.0031)			— — 5.455 (0.2148) 5.420 (0.2134) 0.08 (0.003) 0.12 (0.005)
Valve seat	Width Stem installed height		IN EX IN EX	1.25—1.55 (0.049—0.061) 1.25—1.55 (0.049—0.061) 48.245—48.715 (1.8994—1.9179) 50.315—50.785 (1.9809—1.9994)			2.0 (0.08) 2.0 (0.08) — —
Valve spring	Free length	F20A4, F22A2 engines F22A1 engine	IN EX IN EX	53.16 (2.093) ^{*1} 53.15 (2.093) ^{*2} 55.80 (2.197) ^{*1} 55.78 (2.196) ^{*2} 54.81 (2.158) ^{*1} 54.82 (2.158) ^{*2} 56.26 (2.215) ^{*1} 56.28 (2.216) ^{*2}			— — — — — — — —
Valve guide	I.D. Installed height		IN EX IN EX	5.515—5.530 (0.2171—0.2177) 5.515—5.530 (0.2171—0.2177) 23.75—24.25 (0.935—0.955) 15.05—15.55 (0.593—0.612)			5.55 (0.219) 5.55 (0.219) — —
Rocker arm	Arm-to-shaft clearance		IN EX	0.017—0.050 (0.0007—0.0020) 0.018—0.054 (0.0007—0.0021)			0.08 (0.003) 0.08 (0.003)

*1: CHUO HATSUJO manufactured valve spring

*2: NIHON HATSUJO manufactured valve spring

**Cylinder Head/Valve Train — Section 6
(H23A1, H23A2 engines)**

		MEASUREMENT	STANDARD (NEW)	SERVICE LIMIT
Compression	250 min ⁻¹ (rpm) and wide open throttle kPa (kg/cm ² , psi)	Nominal Minimum Maximum variation	1,250 (12.5, 178) 950 (9.5, 135) 200 (2.0, 28)	
Cylinder head	Warpage Height		— 131.95–132.05 (5.195–5.199)	0.05 (0.002) —
Camshaft	End play Camshaft-to-holder oil clearance Runout Cam lobe height	 IN EX	0.05–0.15 (0.002–0.006) 0.050–0.089 (0.0020–0.0035) * ¹ 0.100–0.139 (0.0039–0.0055) * ² 0.03 (0.001) max. 33.661 (1.3252) 33.725 (1.3278)	0.5 (0.02) 0.15 (0.006) * ¹ 0.20 (0.008) * ² 0.04 (0.002) — —
Valve	Valve clearance Valve stem O. D. Stem-to-guide clearance	IN EX IN EX IN EX	0.07–0.11 (0.003–0.004) * ³ 0.15–0.19 (0.006–0.007) * ³ 6.580–6.590 (0.2591–0.2594) 6.550–6.560 (0.2579–0.2583) 0.02–0.05 (0.001–0.002) 0.05–0.08 (0.002–0.003)	— — 6.55 (0.258) 6.52 (0.257) 0.08 (0.003) 0.11 (0.004)
Valve seat	Width Stem installed height	IN EX IN EX	1.25–1.55 (0.049–0.061) 1.25–1.55 (0.049–0.061) 39.365–39.835 (1.5498–1.5683) 39.165–39.635 (1.5419–1.5604)	2.0 (0.08) 2.0 (0.08) 40.085 (1.5781) 39.885 (1.5703)
Valve spring	Free length	IN EX	47.14 (1.857) 47.14 (1.857)	— —
Valve guide	I. D. Installed height	IN EX IN EX	6.61–6.63 (0.260–0.261) 6.61–6.63 (0.260–0.261) 13.25–13.75 (0.522–0.541) 13.75–14.25 (0.541–0.561)	6.70 (0.264) 6.70 (0.264) — —

*1: Exhaust No. 5 journal

*2: Except exhaust No. 5 journal

*3: Measuring point between camshaft and rocker arm

Standards and Service Limits

Cylinder Head/Valve Train — Section 6 (H22A1, H22A2 engines)

		MEASUREMENT		STANDARD (NEW)	SERVICE LIMIT
Compression	250 min ⁻¹ (rpm) and wide open throttle kPa (kg/cm ² , psi)	Nominal Minimum Maximum variation		1,300 (13.0, 185) 950 (9.5, 135) 200 (2.0, 28)	
Cylinder head	Warpage Height			— 146.95—147.05 (5.785—5.789)	0.05 (0.002) —
Camshaft	End play Camshaft-to-holder oil clearance Runout Cam lobe height	IN Primary Mid Secondary EX Primary Mid Secondary		0.05—0.15 (0.002—0.006) 0.050—0.089 (0.0020—0.0035) 0.03 (0.001) max. 34.041 (1.3402) 36.856 (1.4510) 34.971 (1.3768) 33.745 (1.3285) 36.323 (1.4300) 34.683 (1.3655)	0.5 (0.02) 0.15 (0.006) 0.04 (0.002) — — — — — —
Valve	Valve clearance Valve stem O. D. Stem-to-guide clearance	IN EX IN EX IN EX		0.15—0.19 (0.006—0.007) * ³ 0.17—0.21 (0.007—0.008) * ³ 5.475—5.485 (0.2156—0.2159) 5.475—5.485 (0.2156—0.2159) 0.025—0.055 (0.0010—0.0022) 0.050—0.080 (0.0020—0.0031)	— — 5.445 (0.2144) 5.445 (0.2144) 0.08 (0.003) 0.11 (0.004)
Valve seat	Width Stem installed height	IN EX IN EX		1.30—1.50 (0.051—0.059) 1.25—1.55 (0.049—0.061) 37.465—37.935 (1.4750—1.4935) 37.165—37.635 (1.4632—1.4817)	2.0 (0.08) 2.0 (0.08) 38.185 (1.5033) 37.885 (1.4915)
Valve spring	Free length	IN Outer Inner EX Outer Inner		45.16 (1.778) * ¹ 45.76 (1.802) * ² 41.78 (1.645) * ¹ 41.75 (1.644) * ² 46.72 (1.839) * ¹ 46.74 (1.840) * ² 39.32 (1.548) * ¹ 39.28 (1.546) * ²	— — — — — — — —
Valve guide	I. D. Installed height	IN EX IN EX		5.510—5.530 (0.2169—0.2177) 5.535—5.555 (0.2179—0.2187) 14.55—15.05 (0.573—0.593) 14.95—15.45 (0.589—0.608)	5.55 (0.219) 5.60 (0.220) — —
Rocker arm	Arm-to-shaft clearance	IN EX		0.025—0.052 (0.0010—0.0020) 0.025—0.052 (0.0010—0.0020)	0.08 (0.003) 0.08 (0.003)

*1: CHUO HATSUJO manufactured valve spring

*2: NIHON NATSUJO manufactured valve spring

*3: Measuring point between camshaft and rocker arm

Engine Block — Section 7

	MEASUREMENT	STANDARD (NEW)	SERVICE LIMIT	
Cylinder block	Warpage of deck surface	0.07 (0.003) max.	0.10 (0.004)	
	Bore diameter F20A4, F22A1, F22A2 engines	A 85.010—85.020 (3.3468—3.3472) B 85.000—85.010 (3.3465—3.3468)	85.07 (3.349)	
	H23A1, H23A2, H22A1, H22A2 engines	A 87.010—87.020 (3.4256—3.4260) B 87.000—87.010 (3.4252—3.4256)	87.07 (3.428)	
	Bore Taper	—	0.05 (0.002)	
	Reboring limit F20A4, F22A1, F22A2 engines	—	0.50 (0.020)	
	H23A1, H23A2, H22A1, H22A2 engines	—	0.25 (0.010)	
Piston	Skirt O. D.*1 F20A4, F22A1, F22A2 engines	No Letter (A) 84.980—84.990 (3.3457—3.3461) Letter (B) 84.970—84.980 (3.3453—3.3457)	84.970 (3.3453) 84.960 (3.3449)	
	H23A1, H23A2, H22A1, H22A2 engines	No Letter (A) 86.990—87.003 (3.4248—3.4253) Letter (B) 86.980—86.993 (3.4244—3.4249)	86.980 (3.4244) 86.970 (3.4240)	
	Clearance in cylinder F20A4, F22A1, F22A2 engines	0.020—0.040 (0.0008—0.0016)	0.05 (0.002)	
	H23A1, H23A2, H22A1, H22A2 engines	0.007—0.030 (0.0003—0.0012)	0.04 (0.002)	
	Groove width (for ring) F20A4, F22A1, F22A2 engines	Top 1.220—1.230 (0.0480—0.0484) Second 1.220—1.230 (0.0480—0.0484) Oil 2.805—2.825 (0.1104—0.1112)	1.25 (0.049) 1.25 (0.049) 2.85 (0.112)	
	H23A1, H23A2, H22A1, H22A2 engines	Top 1.230—1.245 (0.0484—0.0490) Second 1.230—1.245 (0.0484—0.0490) Oil 2.805—2.820 (0.1104—0.1110)	1.265 (0.0498) 1.265 (0.0498) 2.85 (0.112)	
	Piston ring	Ring-to-groove clearance	Top 0.035—0.060 (0.0014—0.0024) Second 0.030—0.055 (0.0012—0.0022)	0.13 (0.005) 0.13 (0.005)
		Ring end gap F20A4, F22A1, F22A2 engines	Top 0.20—0.35 (0.008—0.014) Second 0.40—0.55 (0.016—0.022) Oil 0.20—0.70 (0.008—0.028)	0.60 (0.024) 0.70 (0.028) 0.80 (0.031)
		H23A1, H23A2, H22A1, H22A2 engines	Top 0.25—0.35 (0.010—0.014) Second 0.60—0.75 (0.024—0.030) Oil 0.20—0.50 (0.008—0.020) *2 0.20—0.70 (0.008—0.028) *3	0.60 (0.024) 0.90 (0.035) 0.60 (0.024) *2 0.80 (0.031) *3
		Piston pin	O. D. 21.994—22.000 (0.8659—0.8661) Pin-to-piston clearance F20A4, F22A1, F22A2 engines 0.012—0.024 (0.0005—0.0009) H23A1, H23A2, H22A1, H22A2 engines 0.012—0.026 (0.0005—0.0010)	— — —
Connecting rod	Pin-to-rod interference	0.013—0.032 (0.0005—0.0013)	—	
	Small end bore diameter	21.968—21.981 (0.8649—0.8654)	—	
	Large end bore diameter	Nominal Except F20A4 engine 51.0 (2.01) F20A4 engine 48.0 (1.89)	— —	
	End play installed on crankshaft	0.15—0.30 (0.006—0.012)	0.40 (0.016)	
Crankshaft	Main journal diameter	No. 1 journal Except H22A1, H22A2 engines 49.984—50.008 (1.9679—1.9688) H22A1, H22A2 engines 49.976—50.000 (1.9676—1.9685)	— —	
	No. 2 journal	49.976—50.000 (1.9676—1.9685)	—	
	No. 3 journal	49.972—49.996 (1.9674—1.9683)	—	
	No. 4 journal	49.984—50.008 (1.9679—1.9688)	—	
	No. 5 journal	49.988—50.012 (1.9680—1.9690)	—	

*1: Measured at 21.0 mm (0.83 in) on F20A4, F22A1, F22A2 engines and 15.0 mm (0.59 in) on H23A1, H23A2, H22A1, H22A2 engines both from bottom of skirt.

*2: TEIKOKU PISTON RING manufactured piston ring.

*3: RIKEN manufactured piston ring.

(cont'd)

Standards and Service Limits

Engine Block — Section 7 (cont'd)

	MEASUREMENT	STANDARD (NEW)	SERVICE LIMIT	
Crankshaft (cont'd)	Rod journal diameter Except F20A4 engine	47.976—48.000 (1.8888—1.8898)	—	
	F20A4 engine	44.976—45.000 (1.7707—1.7717)	—	
	Taper	0.005 (0.0002) max.	0.006 (0.0002)	
	Out-of-round Except H22A1, H22A2 engines	0.005 (0.0002) max.	0.006 (0.0002)	
	H22A1, H22A2 engines	0.004 (0.0002) max.	0.005 (0.0002)	
End play		0.10—0.35 (0.004—0.014)	0.45 (0.018)	
	Total runout	0.03 (0.001) max.	0.04 (0.002)	
Bearings	Main bearing-to-journal oil clearance			
	No. 1 journal Except H22A1, H22A2 engines	0.013—0.037 (0.0005—0.0015)	0.050 (0.0020)	
	H22A1, H22A2 engines	0.021—0.045 (0.0008—0.0018)	0.050 (0.0020)	
	No. 2 journal	0.021—0.045 (0.0008—0.0018)	0.050 (0.0020)	
	No. 3 journal	0.025—0.049 (0.0010—0.0019)	0.055 (0.0022)	
	No. 4 journal	0.013—0.037 (0.0005—0.0015)	0.050 (0.0020)	
	No. 5 journal	0.009—0.033 (0.0004—0.0013)	0.040 (0.0016)	
	Rod bearing-to-journal oil clearance			
F20A4 engine	0.015—0.049 (0.0006—0.0019)	0.050 (0.0020)		
H22A1, H22A2 engines	0.027—0.055 (0.0011—0.0022)	0.060 (0.0024)		
Except F20A4, H22A1, H22A2 engines	0.021—0.049 (0.0008—0.0019)	0.055 (0.0022)		
Balancer shaft	Journal diameter	No. 1 journal (front)	42.722—42.734 (1.6820—1.6824)	42.71 (1.681)
		No. 1 journal (rear)	20.938—20.950 (0.8243—0.8248)	20.92 (0.824)
		No. 2 journals (front, rear)	38.712—38.724 (1.5241—1.5246)	38.70 (1.524)
		No. 3 journals (front, rear)	34.722—34.734 (1.3670—1.3675)	34.71 (1.367)
	Jurnal taper		0.005 (0.0002)	—
		End play	Front 0.10—0.35 (0.004—0.014)	—
		Rear	0.06—0.18 (0.002—0.007)	—
	Total runout		0.02 (0.001)	0.03 (0.001)
	Oil clearance	No. 1 journal (rear)	0.050—0.075 (0.0020—0.0030)	0.09 (0.004)
		No. 1 journal (front) and No. 3 journals (front, rear)	0.066—0.098 (0.0026—0.0039)	0.12 (0.005)
No. 2 journals (front, rear)		0.076—0.108 (0.0030—0.0043)	0.13 (0.005)	
Balancer shaft bearing	I. D.	No. 1 journal (front)	42.800—42.820 (1.6850—1.6858)	42.83 (1.686)
		No. 1 journal (rear)	21.000—21.013 (0.8268—0.8273)	21.02 (0.828)
		No. 2 journals (front and rear)	38.800—38.820 (1.5276—1.5283)	38.83 (1.529)
		No. 3 journals (front and rear)	34.800—34.820 (1.3701—1.3709)	34.83 (1.371)

Engine Lubrication — Section 8

	MEASUREMENT	STANDARD (NEW)	SERVICE LIMIT
Engine oil	Capacity ℓ F20A4, F22A1, F22A2 engines (US qt, Imp qt)	4.9 (5.2, 4.3) for engine overhaul	
		3.8 (4.0, 3.3) for oil change, including filter	
		3.5 (3.7, 3.1) for oil change without filter	
		5.4 (5.7, 4.8) for engine overhaul	
H23A1, H23A2 engines		4.3 (4.5, 3.8) for oil change, including filter	
		4.0 (4.2, 3.5) for oil change without filter	
		5.9 (6.2, 5.2) for engine overhaul	
H22A1, H22A2 engines		4.8 (5.1, 4.2) for oil change, including filter	
		4.5 (4.8, 4.0) for oil change without filter	
Oil pump	Inner-to-outer rotor radial clearance Pump housing-to-outer rotor radial clearance Pump housing-to-rotor axial clearance	0.02—0.16 (0.001—0.006)	0.20 (0.008)
		0.10—0.19 (0.004—0.007)	0.21 (0.008)
		0.02—0.07 (0.001—0.003)	0.12 (0.005)
Relief valve	Pressure setting at oil temperature 80 °C (176 °F) at idle kPa (kg/cm ² , psi) at 3,000 min ⁻¹ (rpm)	70 (0.7, 10) min.	
		350 (3.5, 50) min.	

Cooling — Section 10

		MEASUREMENT	STANDARD (NEW)
Radiator	Engine coolant capacity (including engine, heater, cooling line and reservoir) ℓ (US qt, Imp qt)	F20A4, F22A1, F22A2 engines	M/T 7.1 (7.5, 6.2) for overhaul 3.5 (3.7, 3.1) for coolant change A/T 7.0 (7.4, 6.2) for overhaul 3.4 (3.6, 3.0) for coolant change
		H23A1, H23A2 engines	M/T 7.6 (8.0, 6.7) for overhaul 4.0 (4.2, 3.5) for coolant change A/T 7.3 (7.7, 6.4) for overhaul 3.7 (3.9, 3.3) for coolant change
	H22A1, H22A2 engines	M/T 7.8 (8.2, 6.9) for overhaul 4.2 (4.4, 3.7) for coolant change	
	Reservoir capacity ℓ (US qt, Imp qt)	0.6 (0.6, 0.5)	
Radiator cap	Opening pressure kPa (kg/cm ² , psi)	95–125 (0.95–1.25, 14–18)	
Thermostat	Start to open	°C (°F)	76–80 (169–176)
	Fully open	°C (°F)	90 (194)
	Valve lift at fully open		8.0 (0.31) min.
Radiator fan	Coolant temperature switch A "ON" / "OFF" °C (°F) Except H22A1, H22A2 engines		90–96 (194–205)/83–88 (181–190)
	H22A1, H22A2 engines Coolant temperature switch B "ON" / "OFF" °C (°F)		92–98 (198–208)/85–90 (185–194) 103–109 (217–228)/ 94–99 (201–210)

Fuel and Emissions — Section 11

		MEASUREMENT	STANDARD (NEW)	
Fuel Pump	Relief valve opening pressure kPa (kg/cm ² , psi)		450–600 (4.5–6.0, 64.0–85.3)	
Pressure regulator	Pressure with regulator vacuum hose disconnected kPa (kg/cm ² , psi)		F22A1, H23A1, H23A2 engines: 255–305 (2.55–3.05, 36–43) F20A4, F22A2, H22A1, H22A2 engines: 245–285 (2.45–2.85, 35–41)	
Fuel tank	Capacity (US gal, Imp gal)		60 (15.9, 13.2)	
Engine	Fast idle min ⁻¹ (rpm)		1,400±200	
	Idle speed min ⁻¹ (rpm) (with headlights and cooling fan off)	F20A4, F22A2 engines F22A1, H23A1 engines H23A2 engine H22A1 engine H22A2 engine	M/T	A/T (<input type="checkbox"/> N or <input type="checkbox"/> P position)
			770±50	770±50
			700±50	700±50
780±50			780±50	
		700±50	—	
		790±50	—	
	Idle CO %		With CATA: 0.1 max. Without CATA: 1.0±1.0	

Standards and Service Limits

Clutch — Section 12

	MEASUREMENT	STANDARD (NEW)	SERVICE LIMIT
Clutch pedal	Pedal height to floor	LHD: 190 (7.48) RHD: 206 (8.11)	— —
	Stroke	135–145 (5.31–5.71)	—
	Free play	9–15 (0.35–0.59)	—
	Pedal play	1.0–7.0 (0.04–0.28)	—
	Disengagement height to floor	LHD: 93 (3.66) min. RHD: 109 (4.29) min.	— —
Flywheel	Clutch surface runout	0.05 (0.002) max.	0.15 (0.006)
Clutch disc	Rivet head depth	1.2–1.8 (0.05–0.07)	0.2 (0.01)
	Thickness	8.4–9.1 (0.33–0.36)	6.0 (0.24)
Pressure plate	Warpage	0.03 (0.001) max.	0.15 (0.006)
	Diaphragm spring fingers alignment	0.6 (0.02) max.	0.8 (0.03)

Manual Transmission — Section 13

	MEASUREMENT	STANDARD (NEW)	SERVICE LIMIT
Transmission oil	Capacity \varnothing (US qt, Imp qt)	1.9 (2.0, 1.7) for oil change 2.0 (2.1, 1.8) for overhaul	
Mainshaft	End play Diameter of ball bearing contact area Diameter of 3rd gear contact area Diameter of ball bearing contact area Runout	0.100–0.160 (0.0039–0.0063) 27.977–27.990 (1.1015–1.1020) 37.984–38.000 (1.4954–1.4961) 27.987–28.000 (1.1018–1.1024) 0.02 (0.0008) max.	Adjust 27.94 (1.100) 37.93 (1.493) 27.94 (1.100) 0.05 (0.002)
Mainshaft 3rd and 4th gears	I. D.	43.009–43.025 (1.6933–1.6939)	43.080 (1.6961)
	End play Thickness 3rd gear M2J4, M2C4, M2K4 M2F5 4th gear M2J4, M2C4, M2K4 M2F5	0.060–0.210 (0.0024–0.0083) 32.42–32.47 (1.276–1.278) 34.92–34.97 (1.375–1.377) 30.92–30.97 (1.217–1.219) 31.42–31.47 (1.237–1.239)	0.30 (0.012) 32.3 (1.27) 34.8 (1.37) 30.8 (1.21) 31.3 (1.23)
Mainshaft 5th gear	I. D. End play Thickness	43.009–43.025 (1.6933–1.6939) 0.060–0.210 (0.0024–0.0083) 30.92–30.97 (1.217–1.219)	43.080 (1.6961) 0.30 (0.012) 30.80 (1.213)
Countershaft	Diameter of needle bearing contact area	38.000–38.015 (1.4961–1.4967)	37.95 (1.494)
	Diameter of ball bearing and needle bearing contact area	24.987–25.000 (0.9837–0.9843)	24.94 (0.982)
	Diameter of 1st gear contact area	39.984–40.000 (1.5742–1.5748)	39.93 (1.572)
	Runout	0.020 (0.0008) max.	0.05 (0.002)
Countershaft 1st gear	I. D.	46.009–46.025 (1.8114–1.8120)	46.08 (1.814)
	End play	0.06–0.23 (0.002–0.009)	0.23 (0.009)
Countershaft 2nd gear	I. D.	47.009–47.025 (1.8507–1.8514)	47.08 (1.854)
	End play Thickness	0.05–0.10 (0.002–0.004) 28.92–28.97 (1.139–1.141)	0.18 (0.007) —

Manual Transmission — Section 13

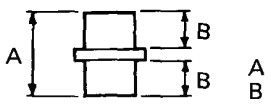
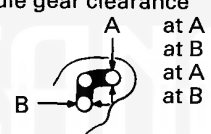
	MEASUREMENT	STANDARD (NEW)	SERVICE LIMIT
Spacer collar (Countershaft 2nd gear)	I. D. O. D. Length	36.480–36.490 (1.4362–1.4366) 41.989–42.000 (1.6531–1.6535) 29.020–29.040 (1.1425–1.1433)	36.50 (1.437) 41.94 (1.651) —
Spacer collar (Mainshaft 4th and 5th gear)	I. D. O. D. Length	 31.002–31.012 (1.2205–1.2209) 37.989–38.000 (1.4956–1.4961) 56.45–56.55 (2.222–2.226) 26.030–26.080 (1.0248–1.0268)	31.06 (1.223) 37.94 (1.494) — 26.01 (1.024)
Reverse idler gear	I. D. Gear-to-reverse gear shaft clearance	20.016–20.043 (0.7880–0.7891) 0.036–0.084 (0.0014–0.0033)	20.090 (0.7909) 0.160 (0.0063)
Syncro ring	Ring-to-gear clearance (ring pushed against gear)	0.85–1.10 (0.033–0.043)	0.40 (0.016)
Dual cone synchro	Clearance (ring pushed against gear) Outer synchro ring-to-synchro cone Synchro cone-to-gear Outer synchro ring-to-gear	0.5–1.0 (0.02–0.04) 0.5–1.0 (0.02–0.04) 0.95–1.68 (0.037–0.066)	0.3 (0.01) 0.3 (0.01) 0.60 (0.024)
Shift fork	Finger thickness Fork-to-synchro sleeve clearance	3rd/4th of the M2F5 Except above	7.4–7.6 (0.291–0.299) 6.2–6.4 (0.244–0.252) 0.35–0.65 (0.014–0.026)
Reverse shift fork	Pawl groove width Fork-to-reverse idle gear clearance Groove width Fork-to-fifth/ reverse shift shaft clearance	 13.0–13.3 (0.51–0.52) 0.5–1.1 (0.02–0.04) 7.05–7.25 (0.278–0.285) 7.4–7.7 (0.29–0.30) 0.05–0.35 (0.002–0.014) 0.4–0.8 (0.02–0.03)	— 1.8 (0.07) — — 0.5 (0.02) 1.0 (0.04)
Shift arm	I. D. Shift arm-to-shaft clearance Shift fork diameter at contact area Shift arm-to-shift fork shaft clearance	15.973–16.000 (0.6289–0.6299) 0.005–0.059 (0.0002–0.0023) 12.90–13.00 (0.508–0.512) 0.2–0.5 (0.01–0.02)	— — — 0.6 (0.02)
Select lever	Pin size of contact area Select lever-to-shift peice clearance Shaft outer diameter Shift arm cover clearance	7.90–8.00 (0.311–0.315) 0.05–0.25 (0.002–0.010) 15.41–15.68 (0.607–0.617) 0.032–0.102 (0.0013–0.0040)	— 0.50 (0.020) — —
Shift lever	O. D. Transmission housing clearance	15.941–15.968 (0.6276–0.6287) 0.012–0.122 (0.0005–0.0048)	— —
Interlock	Bore diameter Shift lever clearance	16.00–16.05 (0.630–0.632) 0.032–0.109 (0.0013–0.0043)	— —

Standards and Service Limits

Automatic Transmission — Section 14

	MEASUREMENT	STANDARD (NEW)	SERVICE LIMIT
Transmission fluid	Capacity \varnothing (US qt, Imp qt)	6.0 (6.3, 5.3) for overhaul 2.4 (2.5, 2.1) for fluid change	
Hydraulic pressure (F20A4/F22A1/ F22A2 engines) kPa (kg/cm ² , psi)	Line pressure at 2,000 min ⁻¹ (rpm) ([N] or [P] position)	800 (8.0, 114) throttle fully-closed 850 (8.5, 121) throttle more than 3/16 open	750 (7.5, 107) throttle more than 3/16 open
	4th clutch pressure at 2,000 min ⁻¹ (rpm) ([D ₄] position)	530 (5.3, 75) throttle fully-closed 850 (8.5, 121) throttle more than 3/16 open	480 (4.8, 68) throttle fully-closed 750 (7.5, 107) throttle more than 3/16 open
	3rd and 2nd clutch pressure at 2,000 min ⁻¹ (rpm) ([D ₃] position)	500 (5.0, 71) throttle fully-closed 850 (8.5, 121) throttle more than 3/16 open	450 (4.5, 64) throttle fully-closed 750 (7.5, 107) throttle more than 3/16 open
	2nd clutch pressure at 2,000 min ⁻¹ (rpm) ([2] position)	800–850 (8.0–8.5, 114–121)	750 (7.5, 107)
	1st and 1st-hold clutch pressure at 2,000 min ⁻¹ (rpm) ([1] position)	800–850 (8.0–8.5, 114–121)	750 (7.5, 107)
	Throttle B pressure Throttle fully-closed Throttle fully-open	0 (0, 0) 800–850 (8.0–8.5, 114–121)	— 750 (7.5, 107)
Hydraulic pressure (H23A1/H23A2 engines) kPa (kg/cm ² , psi)	Line pressure at 2,000 min ⁻¹ (rpm) ([N] or [P] position)	850 (8.5, 121) throttle fully-closed 900 (9.0, 128) throttle more than 3/16 open	800 (8.0, 114) throttle more than 3/16 open
	4th clutch pressure at 2,000 min ⁻¹ (rpm) ([D ₄] position)	530 (5.3, 75) throttle fully-closed 900 (9.0, 128) throttle more than 3/16 open	480 (4.8, 68) throttle fully-closed 800 (8.0, 114) throttle more than 3/16 open
	3rd and 2nd clutch pressure at 2,000 min ⁻¹ (rpm) ([D ₃] position)	500 (5.0, 71) throttle fully-closed 900 (9.0, 128) throttle more than 3/16 open	450 (4.5, 64) throttle fully-closed 800 (8.0, 114) throttle more than 3/16 open
	2nd clutch pressure at 2,000 min ⁻¹ (rpm) ([2] position)	850–900 (8.5–9.0, 121–128)	800 (8.0, 114)
	1st and 1st-hold clutch pressure at 2,000 min ⁻¹ (rpm) ([1] position)	850–900 (8.5–9.0, 121–128)	800 (8.0, 114)
	Throttle B pressure Throttle fully-closed Throttle fully-open	0 (0, 0) 850–900 (8.5–9.0, 121–128)	— 800 (8.0, 114)
Stall speed min ⁻¹ (rpm) (Check with car on level ground)	F20A4/F22A1/F22A2 engines H23A1/H23A2 engines	2,500 2,750	2,350–2,650 2,600–2,900

Automatic Transmission — Section 14

	MEASUREMENT	STANDARD (NEW)	SERVICE LIMIT
Clutch	Clutch initial clearance 1st-hold 1st, 2nd 3rd, 4th Clutch return spring free length 1st, 2nd, 3rd, 4th Clutch disc thickness Clutch plate thickness 1st 2nd F20A4/F22A1/F22A2 engines H23A1/H23A2 engines 3rd, 4th 1st-hold	0.80—1.00 (0.031—0.039) 0.65—0.85 (0.026—0.033) 0.40—0.60 (0.016—0.024) 33.5 (1.32) 1.88—2.00 (0.074—0.079) 1.95—2.05 (0.077—0.081) 2.55—2.65 (0.100—0.104) 1.95—2.05 (0.077—0.081) 2.25—2.35 (0.089—0.093) 1.55—1.65 (0.061—0.065)	— — — 31.5 (1.24) Until grooves worn out. Discoloration ↑ ↓ Discoloration
	Clutch end plate thickness Mark 1 Mark 2 Mark 3 Mark 4 Mark 5 Mark 6 Mark 7 Mark 8 Mark 9	2.05—2.10 (0.081—0.083) 2.15—2.20 (0.085—0.087) 2.25—2.30 (0.089—0.091) 2.35—2.40 (0.093—0.094) 2.45—2.50 (0.096—0.098) 2.55—2.60 (0.100—0.102) 2.65—2.70 (0.104—0.106) 2.75—2.80 (0.108—0.110) 2.85—2.90 (0.112—0.114)	Discoloration ↑ ↓ Discoloration
Valve body	Stator shaft needle bearing contact I. D. Torque converter side Oil pump side Oil pump gear thrust clearance Oil pump gear-to-body clearance Drive Driven Oil pump driven gear I. D. Oil pump shaft O. D.	27.000—27.021 (1.0630—1.0638) 29.000—29.013 (1.1417—1.1422) 0.03—0.05 (0.001—0.002) 0.210—0.265 (0.0083—0.0104) 0.070—0.125 (0.0028—0.0049) 14.016—14.034 (0.5518—0.5525) 13.980—13.990 (0.5504—0.5508)	Wear or damage — 0.07 (0.003) — — Wear or damage Wear or damage
Shifting device, parking brake and throttle control system	Reverse shift fork finger thickness Parking brake pawl Parking brake gear Throttle cam stopper height	5.90—6.00 (0.232—0.236) — — 17.00—17.10 (0.669—0.673)	5.40 (0.213) Wear or other defect Wear or other defect —
Servo body	Shift fork shaft bore I. D. Shift fork shaft valve bore I. D.	14.000—14.010 (0.5512—0.5516) 37.000—37.039 (1.4567—1.4582)	— 37.045 (1.4585)
Regulator valve body	Sealing ring contact I. D.	35.000—35.025 (1.3780—1.3789)	35.050 (1.3799)
Accumulator body	Sealing ring contact I. D.	32.000—32.013 (1.2598—1.2604)	32.050 (1.2618)
Stator shaft	Sealing ring contact I. D.	29.000—29.013 (1.1417—1.1422)	29.050 (1.1437)
Transmission	Diameter of needle bearing contact area On mainshaft of stator shaft On mainshaft of 3rd gear collar On mainshaft of 4th gear collar On countershaft of 1st gear collar On countershaft of 4th gear On countershaft of parking gear On countershaft of reverse gear On secondary shaft of 1st gear On secondary shaft of 2nd gear On reverse idler gear shaft Inside diameter Mainshaft 3rd gear Mainshaft 4th gear	22.984—23.000 (0.9049—0.9055) 45.984—46.000 (1.8104—1.8110) 31.984—32.000 (1.2592—1.2598) 40.984—41.000 (1.6135—1.6142) 31.975—31.991 (1.2589—1.2595) 39.984—40.000 (1.5742—1.5748) 35.979—36.000 (1.4165—1.4173) 31.975—31.991 (1.2589—1.2595) 31.975—31.991 (1.2589—1.2595) 14.990—15.000 (0.5902—0.5906) 52.000—52.019 (2.0472—2.0480) 38.005—38.021 (1.4963—1.4969)	Wear or damage ↑ ↓ Wear or damage

(cont'd)

Standards and Service Limits

Automatic Transmission — Section 14 (cont'd)

	MEASUREMENT	STANDARD (NEW)				SERVICE LIMIT
		Wire Dia.	O. D.	Free Length	No. of Coils	
Transmission (cont'd)	Inside diameter					Wear or damage ↑
	Countershaft 1st gear	47.000—47.016 (1.8504—1.8510)				
	Countershaft 4th gear	38.000—38.016 (1.4961—1.4967)				
	Countershaft reverse gear	42.000—42.016 (1.6535—1.6542)				↓ Wear or damage
	Countershaft idler gear	48.000—48.016 (1.8898—1.8904)				
	Secondary shaft 1st gear	36.000—36.016 (1.4173—1.4179)				Wear or damage
	Secondary shaft 2nd gear	37.000—37.016 (1.4567—1.4573)				
	Reverse idler gear shaft holder	14.800—14.824 (0.5827—0.5836)				
	Mainshaft 3rd gear collar length	19.50—19.55 (0.768—0.770)				—
	Mainshaft 4th gear collar length	47.50—47.55 (1.870—1.872)				Wear or damage
	Countershaft 1st gear collar length	27.50—27.55 (1.083—1.085)				Wear or damage
	Thrust washer thickness					
	Countershaft 1st gear	1.45—1.50 (0.057—0.059)				Wear or damage
	Countershaft idler gear	3.45—3.55 (0.136—0.140)				Wear or damage
	Countershaft parking gear length	25.030—25.048 (0.9854—0.9861)				Wear or damage
	Secondary shaft 1st gear distance collar length	4.95—5.00 (0.195—0.197)				Wear or damage
	Secondary shaft 2nd gear thrust washer thickness	4.350—4.450 (0.1713—0.1752)				Wear or damage
	Secondary shaft 2nd gear spline washer thickness 35 x 53 mm	4.02—4.05 (0.158—0.159)				—
		4.07—4.10 (0.160—0.161)				—
		4.12—4.15 (0.162—0.163)				—
		4.17—4.20 (0.164—0.165)				—
		4.22—4.25 (0.166—0.167)				—
		4.27—4.30 (0.168—0.169)				—
		4.32—4.35 (0.170—0.171)				—
		4.37—4.40 (0.172—0.173)				—
		4.42—4.45 (0.174—0.175)				—
		STANDARD (NEW)				
	MEASUREMENT	Wire Dia.	O. D.	Free Length	No. of Coils	
Spring	Regulator valve spring A					
	F20A4/F22A1/F22A2 engines	1.80 (0.071)	14.70 (0.579)	85.40 (3.362)	16.50	
	H23A1/H23A2 engines	1.80 (0.071)	14.70 (0.579)	87.80 (3.457)	16.50	
	Regulator valve spring B	1.80 (0.071)	9.60 (0.378)	44.00 (1.732)	12.70	
	Stator reaction spring	4.50 (0.177)	26.40 (1.039)*	30.30 (1.193)	1.920	
	Torque converter check valve spring	1.10 (0.043)	8.40 (0.331)	38.20 (1.504)	14.00	
	Relief valve spring	1.00 (0.039)	8.40 (0.331)	39.10 (1.539)	15.10	
	Cooler relief valve spring	1.00 (0.039)	8.40 (0.331)	46.80 (1.843)	10.80	
	2nd orifice control valve spring	0.60 (0.024)	6.60 (0.260)	58.30 (2.295)	15.80	
	Orifice control valve spring	0.70 (0.028)	6.60 (0.260)	52.50 (2.067)	18.40	
	4th exhaust valve spring	0.90 (0.035)	7.10 (0.280)	60.80 (2.394)	28.90	
	Throttle valve B adjusting spring	0.80 (0.031)	6.20 (0.244)	30.00 (1.181)	8.00	
	Throttle valve B spring	1.40 (0.055)	8.50 (0.335)	41.50 (1.634)	10.50	
		1.40 (0.055)	8.50 (0.335)	41.50 (1.634)	11.20	
		1.40 (0.055)	8.50 (0.335)	41.60 (1.638)	12.40	
	1-2 shift valve spring	1.00 (0.039)	8.60 (0.339)	41.30 (1.626)	16.90	
	2-3/3-4 shift valve spring	0.90 (0.035)	7.60 (0.299)	57.00 (2.244)	26.80	
	1st-hold accumulator spring	4.00 (0.157)	25.00 (0.984)	64.70 (2.547)	7.30	
	1st accumulator spring	1.80 (0.071)	16.30 (0.642)	115.40 (4.543)	18.60	
	4th accumulator spring	2.90 (0.114)	22.00 (0.866)	90.10 (3.547)	10.90	
	2nd accumulator spring	3.50 (0.138)	22.00 (0.866)	77.10 (3.035)	10.00	
	3rd accumulator spring	2.80 (0.110)	17.50 (0.689)	94.20 (3.709)	16.10	
	Lock-up shift valve spring	0.90 (0.035)	7.60 (0.299)	73.70 (2.902)	32.00	
	Lock-up timing valve spring	0.80 (0.031)	6.60 (0.260)	51.10 (2.012)	14.70	
	Servo control valve spring	1.00 (0.039)	8.10 (0.319)	52.60 (2.071)	22.40	
	CPC valve spring	1.40 (0.055)	9.40 (0.370)	33.00 (1.299)	10.50	
	Modulator valve spring	1.40 (0.055)	9.40 (0.370)	33.00 (1.299)	10.50	
	Lock-up control valve spring	0.70 (0.028)	6.60 (0.260)	38.00 (1.496)	14.10	
	3rd kick-down spring	1.00 (0.039)	7.60 (0.299)	48.30 (1.902)	15.60	
	3-2 kick-down spring	1.20 (0.047)	7.10 (0.280)	46.90 (1.846)	20.60	

*: I. D.

Differential (Manual transmission) — Section 15

	MEASUREMENT	STANDARD (NEW)	SERVICE LIMIT
Differential carrier	Pinion shaft contact area I. D.	18.000—18.018 (0.7087—0.7094)	—
	Carrier-to-pinion shaft clearance	0.017—0.047 (0.0007—0.0019)	0.10 (0.004)
	Driveshaft contact area I. D.	28.005—28.025 (1.1026—1.1033)	—
	Carrier-to-driveshaft clearance	0.025—0.066 (0.0010—0.0026)	0.12 (0.005)
		R L	0.15 (0.006)
Differential pinion gear	Backlash I. D.	0.05—0.15 (0.002—0.006)	Adjust
	Pinion gear-to-pinion shaft clearance	18.042—18.066 (0.7103—0.7113) 0.055—0.095 (0.0022—0.0037)	— 0.15 (0.006)
Tapered roller bearing preload	Starting torque N·m (kg·cm, lb·in)	1.4—2.6 (14—26, 12—23)	Adjust

Differential (Automatic transmission) — Section 15

	MEASUREMENT	STANDARD (NEW)	SERVICE LIMIT
Differential carrier	Pinion shaft contact area I. D.	18.000—18.018 (0.7087—0.7094)	—
	Carrier-to-pinion shaft clearance	0.013—0.047 (0.0005—0.0019)	0.10 (0.004)
	Driveshaft contact area I. D.	28.005—28.025 (1.1026—1.1033)	—
	Carrier-to-driveshaft clearance	0.025—0.066 (0.0010—0.0026)	0.12 (0.005)
Differential pinion gear	Backlash I. D.	0.08—0.15 (0.003—0.006)	Adjust
	Pinion gear-to-pinion shaft clearance	18.042—18.066 (0.7103—0.7113) 0.055—0.095 (0.0022—0.0037)	— 0.12 (0.005)
Tapered roller bearing preload	Starting torque	New bearings 2.8—4.0 (28—40, 24—35)	Adjust
	N·m (kg·cm, lb·in)	Reused bearingse 2.5—3.7 (25—37, 22—32)	

Steering — Section 17

	MEASUREMENT	STANDARD (NEW)
Steering wheel	Play at steering wheel circumference	0—10 (0—0.4)
	Starting load at steering wheel circumference N (kg, lbs)	
	Engine running	30 (3.0, 6.6)
	When the hydraulic system to the speed sensor is cut off	50 (5.0, 11.0)
Gear box	Angle of rack-guide-screw loosened from locked position	20° ^{+5°} / ₀
Pump	Pump pressure with shut-off valve closed (speed: idle. Do not run for more than 5 seconds). kPa (kg/cm ² , psi)	7,000—8,000 (70—80, 995—1,138)
Power steering fluid	Recommended fluid	Honda power steering fluid-V
	Fluid capacity ℓ (US qt, Imp qt)	System 1.70 (1.80, 1.50) Reservoir 0.50 (0.53, 0.44)
Power steering belt *	Deflection with 100 N (10 kg, 22 lbs) between pulleys	13.5—16.5 (0.53—0.65) with used belt 9.5—11.5 (0.37—0.45) with new belt
	Belt tension N (kg, lbs) Measured with belt tension gauge	350—500 (35—50, 77—110) with used belt 700—900 (70—90, 154—198) with new belt

*When using a new belt, adjust deflection or tension to new values. Run the engine for 5 minutes then turn it off. Readjust deflection or tension to used belt values.

Standards and Service Limits

Suspension — Section 18

		MEASUREMENT		STANDARD (NEW)		
Wheel alignment (2WS)	Camber	Front	0°00' ± 1°			
		Rear	-0°45' ± 1°			
	Caster	Front	2°40' ± 1°			
	Total toe	Front	0 ± 2.0 (0 ± 0.08)			
		Rear	IN 2.0 ± 2.0 (0.08 ± 0.08)			
	Front wheel turning angle	Inward wheel	36°20' ± 2°			
		Outward wheel	29°40' (reference)			
Wheel alignment (4WS)	Camber	Front	0°00' ± 1°			
		Rear	-0°45' ± 30'			
	Caster	Front	2°40' ± 1°			
	Total toe	Front	0 ± 2.0 (0 ± 0.08)			
			Rear	IN 2.0 ± 2.0 (0.08 ± 0.08)		
		Wheel turning angle	Inward wheel	36°20' ± 2°		
		Outward wheel	6°00' ± 1°			
		Front	29°40' (reference)			
		Rear	6°20' (reference)			
Wheel	Rim runout (Aluminum wheel)	Axial	0 - 0.7 (0 - 0.03)			
		Radial	0 - 0.7 (0 - 0.03)			
	Rim runout (Steel wheel)	Axial	0 - 1.0 (0 - 0.04)			
		Radial	0 - 1.0 (0 - 0.04)			
Wheel bearing	End play	Front	0 - 0.05 (0 - 0.002)			
		Rear	0 - 0.05 (0 - 0.002)			

Brake — Section 19

		MEASUREMENT		STANDARD (NEW)		SERVICE LIMIT	
Parking brake lever		Play in stroke 200 N (20 kg, 44 lbs) lever force		To be locked when pulled 6-10 notches		—	
Foot brake pedal	Pedal height (with floor mat removed)	M/T	LHD: 165 (6.50) RHD: 180 (7.09)			—	
	Free play	A/T	186 (7.32) 1 - 5 (1/16 - 13/64)			—	
Master cylinder	Piston-to-pushrod clearance	Without ABS	0 - 0.4 (0 - 0.02)			—	
		With ABS	0 - 0.2 (0 - 0.01)			—	
Disc brake	Disc thickness	Front	23.0 (0.91)			21.0 (0.83)	
		Rear	10.0 (0.39)			8.0 (0.31)	
	Disc runout	Front	—			0.10 (0.004)	
		Rear	—			0.10 (0.004)	
	Disc parallelism	Front and rear	—			0.015 (0.0006)	
	Pad thickness	Front	12.5 (0.49)			1.6 (0.06)	
			11.0 (0.43) *			1.6 (0.06) *	
		Rear	9.0 (0.35)			1.6 (0.06)	
	Characteristics	Vacuum mmHg	Pedal Pressure kg (lbs)			Line Pressure kPa (kg/cm², psi)	
	Without ABS	0	20 (44)			1,030 (10.3, 146) min.	
300		20 (44)			5,690 (56.9, 809) min.		
500		20 (44)			8,030 (80.3, 1,142) min.		
With ABS	0	20 (44)			790 (7.9, 112) min.		
	300	20 (44)			6,320 (63.2, 899) min.		
	500	20 (44)			7,880 (78.8, 1,121) min.		

* Cars with H23A2, H22A1 and H22A2 engines

Air Conditioning — Section 22

	MEASUREMENT	STANDARD (NEW)
Air conditioning system	Lubricant type: SP-10 (P/N 38899-P13-003) (For refrigerant: HFC-134a (R-134a)) Lubricant capacity m l (fl oz, Imp oz)	Condenser Evaporator Line or hose Receiver 10 (1/3, 0.4) 30 (1, 1.1) 10 (1/3, 0.4) 10 (1/3, 0.4)
Compressor	Lubricant type: SP-10 (P/N 38899-P13-003) (For refrigerant: HFC-134a (R-134a)) Lubricant capacity m l (fl oz, Imp oz) Stator coil resistance at 20 °C (68°F) Ω Pulley-to-pressure plate clearance	120–140 (4–4-2/3, 4.2–4.9) 3.05–3.35 0.5±0.15 (0.02±0.006)
Compressor belt *1	Deflection with 100 N (10 kg, 22 lbs) between the pulleys	10.0–12.0 (0.39–0.47) with used belt 4.5–7.0 (0.18–0.28) with new belt
	Belt tension N (kg, lbs) Measured with belt tension gauge Except H22A1, H22A2 engines H22A1, H22A2 engines	450–600 (45–60, 99–132) with used belt 950–1,150 (95–115, 209–254) with new belt 1,000–1,150 (100–115, 220–254) with new belt

*1: When using a new belt, adjust deflection or tension to new values. Run the engine for 5 minutes then turn it off. Readjust deflection or tension to used belt values.

Electrical — Section 23

	MEASUREMENT	STANDARD (NEW)
Ignition coil	Rated voltage V Primary winding resistance Ω at 25°C (77°F) Secondary winding resistance kΩ at 25°C (77°F)	12 0.6–0.8 12.9–19.2 *2, 14.4–21.6 *3
Spark plug	Type Gap	See section 23 (Base manual code No. 62SS000) 1.0–1.1 (0.039–0.043)
Ignition timing	At idle	15°±2° (Red) BTDC
Alternator belt *1	Deflection with 100 N (1.0 kg, 22 lbs) between pulleys Except H22A1, H22A2 engines: H22A1, H22A2 engines: Except H22A1, H22A2 engines: H22A1, H22A2 engines:	10.0–12.0 (0.39–0.47) with used belt 10.5–12.5 (0.41–0.49) with used belt 8.5–11.0 (0.33–0.43) with new belt 8.0–10.0 (0.31–0.39) with new belt
	Belt tension N (kg, lbs) measured with belt tension gauge Except H22A1, H22A2 engines: H22A1, H22A2 engines:	300–450 (30–45, 66–99) with used belt 500–700 (50–70, 110–154) with new belt 550–750 (55–75, 121–165) with new belt

*1: When using a new belt, adjust deflection or tension to new values. Run the engine for 5 minutes then turn it off. Readjust deflection or tension to used belt values.

*2: F20A4, F22A2, H23A2, H22A2 engines

*3: F22A1, H23A1, H22A1 engines

(cont'd)

Standards and Service Limits

Electrical — Section 23 (cont'd)

	MEASUREMENT	STANDARD (NEW)	SERVICE LIMIT
Alternator (NIPPONDENSO)	Output 13.5 V at hot A Coil resistance (rotor) Ω Slip ring O.D. Brush length Brush spring tension g (oz)	80/85 ^{**} , 90/98 ^{**5} , 95/102 ^{**6} 2.1–2.5 14.4 (0.57) 10.5 (0.41) 300–360 (10.6–12.7)	— — 12.8 (0.50) 5.5 (0.22) —
Starter motor (MITSUBA 1.4 kW)	Type Mica depth Commutator runout Commutator O.D. Brush length Brush spring tension (new) N (kg, lb)	Spur gear reduction, Permanent magnet 0.4–0.5 (0.016–0.020) 0–0.02 (0–0.001) 28.0–28.1 (1.102–1.106) 15.8–16.2 (0.62–0.64) 16–18 (1.6–1.8, 3.5–4.0)	0.15 (0.006) 0.05 (0.002) 27.5 (1.083) 11.0 (0.43) —
Starter motor (MITSUBA 1.6 kW)	Type Mica depth Commutator runout Commutator O.D. Brush length Brush spring tension (new) N (kg, lb)	Spur gear reduction, Permanent magnet 0.4–0.5 (0.016–0.020) 0–0.02 (0–0.001) 28.0–28.1 (1.102–1.106) 15.8–16.2 (0.62–0.64) 16–18 (1.6–1.8, 3.5–4.0)	0.15 (0.006) 0.05 (0.002) 27.5 (1.083) 11.0 (0.43) —

**4: F20A4, F22A1, F22A2 engines

**5: H23A1, H23A2 engines

**6: H22A1, H22A2 engines



Design Specifications

	ITEM	METRIC (ENGLISH)	NOTES
DIMENSIONS	Overall Length Overall Width Overall Height Wheelbase Track Ground Clearance Seating Capacity	4,440 mm (174.8 in) 1,765 mm (69.5 in) 1,290 mm (50.8 in) 2,550 mm (100.4 in) 1,525/1,515 mm (60.0/59.6 in) 145 mm (5.7 in) Four	
WEIGHT	See page 3-20 to 3-21		
ENGINE	Type F20A4, F22A1, F22A2 engines H23A1, H23A2 engines H22A1, H22A2 engines Cylinder Arrangement Bore and Stroke F20A4 engine F22A1, F22A2 engines H23A1, H23A2 engines H22A1, H22A2 engines Displacement F20A4 engine F22A1, F22A2 engines H23A1, H23A2 engines H22A1, H22A2 engines Compression Ratio F20A4 engine F22A1 engine F22A2 engine H23A1, H23A2 engines H22A1, H22A2 engines Valve Train F20A4, F22A1, F22A2 engines H23A1, H23A2 engines H22A1, H22A2 engines Lubrication System Oil Pump Displacement at 6,000 min ⁻¹ (rpm) F20A4, F22A1, F22A2 engines Except F20A4, F22A1, F22A2 engines Water Pump Displacement at 6,000 min ⁻¹ (rpm) F20A4, F22A1, F22A2 engines H23A1, H23A2 engines H22A1, H22A2 engines Recommended Gasoline F20A4, H23A1, H23A2, H22A1, H22A2 engines F22A1 engine F22A2 engine *1	Water-cooled, 4-stroke SOHC gasoline engine Water-cooled, 4-stroke DOHC gasoline engine Water-cooled, 4-stroke DOHC VTEC gasoline engine Inline 4-cylinder, transverse 85.0 x 88.0 mm (3.35 x 3.46 in) 85.0 x 95.0 mm (3.35 x 3.74 in) 87.0 x 95.0 mm (3.43 x 3.74 in) 87.0 x 90.7 mm (3.43 x 3.57 in) 1,997 cm ³ (121.9 cu-in) 2,156 cm ³ (131.6 cu-in) 2,259 cm ³ (137.9 cu-in) 2,157 cm ³ (131.6 cu-in) 9.5:1 8.8:1 8.9:1 9.8:1 10.0:1 Belt driven, SOHC 4 valve per cylinder Belt driven, DOHC 4 valve per cylinder Belt driven, DOHC VTEC 4 valve per cylinder Forced and wet sump, trochoid pump 54.3 ℓ (57.4 US qt, 47.8 Imp qt)/minute 59.1 ℓ (62.5 US qt, 52.0 Imp qt)/minute 165 ℓ (174 US qt, 145 Imp qt)/minute 159 ℓ (168 US qt, 140 Imp qt)/minute 163 ℓ (172 US qt, 143 Imp qt)/minute Premium-UNLEADED grade gasoline with 95 Research Octane Number (RON) or higher UNLEADED grade gasoline with 91 Research Octane Number (RON) or higher LEADED grade gasoline with 91 Research Octane Number (RON) or higher	F22A2 engines *1: UNLEADED grade gasoline with 91 RON or higher may also be used.
STARTER	Type Normal Output Normal Voltage Hour Rating Direction of Rotation Weight	Gear reduction 1.4 kW, 1.6 kW 12 V 30 seconds Clockwise as viewed from gear end 3.7 kg (8.2 lbs)	
CLUTCH	Clutch Type Clutch Facing Area	M/T A/T M/T Single plate dry, diaphragm spring Torque converter 203 cm ² (31 sq-in)	

(cont'd)

Design Specifications

(cont'd)

	ITEM		METRIC (ENGLISH)				NOTES	
TRANSMISSION	Type	M/T A/T	Synchronized 5-speed forward, 1 reverse Electronically controlled 4-speed automatic, 1 reverse Direct 1:1					
	Primary Reduction							
	Manual transmission		F20A4, F22A1 engines	F22A2 engine	H23A1, H23A2 engines	H22A1, H22A2 engines		
	Gear Ratio	1st		3.307	3.307	3.307		3.307
		2nd		1.809	1.809	1.809		1.950
		3rd		1.269	1.230	1.269		1.360
		4th		0.966	0.933	0.966		1.071
		5th		0.787	0.757	0.757		0.870
		Reverse		3.000	3.000	3.000		3.000
	Final Reduction Gear	Type Ratio	Single helical gear 4.266			4.266 *1 4.062 *2		*1: H22A1 engine *2: H22A2 engine
Automatic transmission		F20A4, F22A1, H23A1 H23A2 engines		F22A2 engine				
Gear Ratio	1st		2.705		2.705			
	2nd		1.366		1.428			
	3rd		1.028		1.028			
	4th		0.750		0.731			
	Reverse		2.047		2.047			
Final Reduction Gear	Type Ratio	Single helical gear 4.285						
AIR CONDITIONING	Cooling Capacity		3,700 Kcal/h (14,680 BTU/h)					
	Compressor	Type/Make No. of Cylinder Capacity Max. Speed Lubricant Capacity Lubricant Type	Scroll/HADSYS — 85.7 cm ³ /rev (5.23 cu-in/rev) 10,000 min ⁻¹ (rpm) 120 m l (4.1 fl oz, 4.2 Imp oz) SP-10 (P/N 38899-P13-003)					
	Condenser	Type	Corrugated fin					
	Evaporator	Type	Corrugated fin					
	Blower	Type Motor Input Speed Control Max. Capacity	Sirocco fan 220 W/12 V 4-speed 460 m ³ /h (16,247 cu-ft/h)					
	Temperature Control		Air-mix type					
	Compressor Clutch	Type Power Consumption	Dry, single plate, poly-V-belt drive 42 W max./12V at 20°C (68°F)					
	Refrigerant	Type Quantity	LHD	HFC-134a (R-134a) 650 ⁰ / ₋₅₀ g (22.9 ⁰ / _{-1.8} oz)				
			RHD	700 ⁰ / ₋₅₀ g (24.7 ⁰ / _{-1.8} oz)				

	ITEM		METRIC (ENGLISH)	NOTES
STEERING SYSTEM	Type		Power assisted, rack and pinion	
	Overall Ratio		2WS: 15.86 4WS: 15.1	
	Turns, Lock-to-Lock		2WS: 2.91 4WS: 2.77	
	Steering Wheel Diameter		380 mm (15.0 in)	
SUSPENSION	Type	Front	Independent double wishbone, coil spring with stabilizer	
		Rear	Independent double wishbone, coil spring with stabilizer	
	Shock Absorber	Front and Rear	Telescopic, hydraulic nitrogen gas-filled	
WHEEL ALIGNMENT	Camber	Front	0°00'	
		Rear	-0°45'	
	Caster	Front	2°40'	
	Total Toe	Front	0 mm (0 in)	
		Rear	In 2.0 mm (0.08 in)	
BRAKE SYSTEM	Type	Front	Power-assisted self-adjusting ventilated disc	
		Rear	Power assisted self-adjusting solid disc	
	Pad Surface Area	Front	58.0 cm ² x 2 (8.99 sq-in x 2)	
		Rear	49.4 cm ² x 2 (7.66 sq-in x 2)	
	Parking Brake	Type	27.9 cm ² x 2 (4.32 sq-in x 2)	Mechanical actuating, rear two wheel brakes
TIRE	Size and Pressure		See tire information label on the driver's door jamb.	
ELECTRICAL	Battery		12 V-55 AH/5HR * ¹ , 12 V-52 AH/5HR * ²	
			12 V-38 AH/5HR * ³	
	Starter		12 V-1.6 kW * ⁴ , 12 V-1.4 kW * ⁵	
	Alternator		12 V-95 A * ⁶ , 12 V-90 A * ⁷ , 12 V-80 A * ⁸	
	Fuses	In Under-dash Fuse/Relay Box	7.5 A, 10 A, 15 A, 20 A, 30 A	
		In Under-hood Fuse/Relay Box	7.5 A, 10 A, 15 A, 20 A, 30 A, 40 A, 50 A, 60 A, 100 A	
	Headlights	Inside	12 V-55 W * ⁹ , 12 V-65 W * ¹⁰	
		Outside	12 V-60/55 W * ⁹ , 12 V-55 W * ¹⁰	
	Front Turn Signal Lights		12 V-21 W	
	Front Position Lights		12 V-5 W	
	Side Turn Signal Lights		12 V-5 W	
	Rear Turn Signal Lights		12 V-21 W	
	Brake/Taillights		12 V-21/5 W	
	Back-up Lights		12 V-21 W	
	Rear Fog Light * ¹¹		12 V-21 W	
	License Plate Lights		12 V-5 W * ¹² , 12 V-8 W * ¹³	
	High Mount Brake Light * ¹⁴		12 V-21 CP	
Interior Light		12 V-8 W		
Trunk Lights		12 V-3.4 W		
Gauge Lights		12 V-1.4 W, 1.7 W, 3.0 W		
Indicator Lights		12 V-1.12 W, 1.4 W, 1.7 W, 3.0 W, 3.2 W		
Illumination and Pilot Lights		12 V-0.56 W, 0.84 W, 0.91 W, 1.12 W, 1.4 W, LED		
Heater Illumination Lights		12 V-1.4 W		

*¹: H23A2 (KS model), H22A1, H22A2 engines
 *²: H23A2 (except KS model), F20A4, H23A1 engines
 *³: F22A1, F22A2 engines
 *⁴: Except F20A4 (M/T), F22A1 (M/T), F22A2 engines
 *⁵: F20A4 (M/T), F22A1 (M/T), F22A2 engines
 *⁶: H22A1, H22A2 engines
 *⁷: H23A1, H23A2 engines

*⁸: F20A4, F22A1, F22A2 engines
 *⁹: Except KY model
 *¹⁰: KY model
 *¹¹: Except KQ, KY, KT models
 *¹²: Except KY, KT models
 *¹³: KY, KT models
 *¹⁴: KQ, KY models

Design Specifications

European Models

	ITEM	METRIC (ENGLISH)	NOTES
WEIGHT	Curb Weight		
	2.0 ℓ M/T	1,220 kg (2,690 lbs) 1,195 kg (2,634 lbs)	KF, KG *1, KS, KE KG *2
	2.0 ℓ A/T	1,245 kg (2,745 lbs) 1,220 kg (2,690 lbs)	KF, KG *1, KS, KE KG *2
	2.0 ℓ M/T with ABS	1,235 kg (2,723 lbs) 1,210 kg (2,668 lbs)	KF, KG *1, KS, KE KG *2
	2.0 ℓ A/T with ABS	1,260 kg (2,778 lbs) 1,235 kg (2,723 lbs)	KF, KG *1, KS, KE KG *2
	2.3 ℓ M/T with ABS	1,250 kg (2,756 lbs) 1,225 kg (2,701 lbs)	KF, KG *1, KS, KE KG *2
	2.3 ℓ A/T with ABS	1,275 kg (2,811 lbs) 1,250 kg (2,756 lbs)	KF, KG *1, KS, KE KG *2
	2.3 ℓ M/T with ABS, 4WS	1,270 kg (2,800 lbs) 1,245 kg (2,745 lbs)	KF, KG *1, KS, KE KG *2
	2.3 ℓ A/T with ABS, 4WS	1,295 kg (2,855 lbs) 1,270 kg (2,800 lbs)	KF, KG *1, KS, KE KG *2
	2.2 ℓ VTEC M/T	1,305 kg (2,877 lbs) 1,280 kg (2,822 lbs)	KF, KG *1, KS, KE KG *2
	Weight Distributions (Front/Rear)		
	2.0 ℓ M/T	760 kg (1,676 lbs) / 460 kg (1,014 lbs)	KF, KG *1, KS, KE KG *2
	2.0 ℓ A/T	785 kg (1,731 lbs) / 460 kg (1,014 lbs)	KF, KG *1, KS, KE KG *2
	2.0 ℓ M/T with ABS	773 kg (1,704 lbs) / 462 kg (1,019 lbs)	KF, KG *1, KS, KE KG *2
	2.0 ℓ A/T with ABS	798 kg (1,759 lbs) / 462 kg (1,019 lbs)	KF, KG *1, KS, KE KG *2
	2.3 ℓ M/T with ABS	785 kg (1,731 lbs) / 465 kg (1,025 lbs)	KF, KG *1, KS, KE KG *2
	2.3 ℓ A/T with ABS	810 kg (1,786 lbs) / 465 kg (1,025 lbs)	KF, KG *1, KS, KE KG *2
	2.3 ℓ M/T with ABS, 4WS	785 kg (1,731 lbs) / 485 kg (1,069 lbs)	KF, KG *1, KS, KE KG *2
	2.3 ℓ A/T with ABS, 4WS	810 kg (1,786 lbs) / 485 kg (1,069 lbs)	KF, KG *1, KS, KE KG *2
	2.2 ℓ VTEC M/T	808 kg (1,781 lbs) / 497 kg (1,096 lbs)	KF, KG *1, KS, KE KG *2
	Max. Permissible Weight (MPW)	1,720 kg (3,792 lbs)	

KG *1: KG type except Netherlands, KG *2: KG type for Netherlands (half tank of gasoline).

Except European Models

	ITEM	METRIC (ENGLISH)	NOTES
WEIGHT	Curb Weight		
	2.2 ℓ M/T	1,230 kg (2,712 lbs) 1,260 kg (2,778 lbs)	KQ KY
	2.2 ℓ A/T	1,255 kg (2,767 lbs) 1,285 kg (2,833 lbs)	KQ KY
	2.2 ℓ M/T with SRS 2.2 ℓ A/T with SRS	1,232 kg (2,716 lbs) 1,257 kg (2,771 lbs)	KQ KQ
	2.3 ℓ M/T with SRS, 4WS 2.3 ℓ A/T with SRS, 4WS	1,270 kg (2,800 lbs) 1,295 kg (2,855 lbs)	KQ KQ
	2.3 ℓ M/T with ABS, SRS 2.3 ℓ A/T with ABS, SRS	1,300 kg (2,866 lbs) 1,325 kg (2,921 lbs)	KM KM
	2.3 ℓ M/T with ABS, SRS, 4WS 2.3 ℓ A/T with ABS, SRS, 4WS	1,300 kg (2,866 lbs) 1,325 kg (2,921 lbs)	KQ KQ
	2.2 ℓ VTEC M/T	1,315 kg (2,899 lbs)	KQ
	Weight Distributions (Front/Rear)		
	2.2 ℓ M/T	755 kg (1,665 lbs) / 475 kg (1,047 lbs) 775 kg (1,709 lbs) / 485 kg (1,069 lbs)	KQ KY
	2.2 ℓ A/T	780 kg (1,720 lbs) / 475 kg (1,047 lbs) 800 kg (1,764 lbs) / 485 kg (1,069 lbs)	KQ KY
	2.2 ℓ M/T with SRS 2.2 ℓ A/T with SRS	757 kg (1,669 lbs) / 475 kg (1,047 lbs) 782 kg (1,724 lbs) / 475 kg (1,047 lbs)	KQ KQ
	2.3 ℓ M/T with SRS, 4WS 2.3 ℓ A/T with SRS, 4WS	775 kg (1,709 lbs) / 495 kg (1,091 lbs) 800 kg (1,764 lbs) / 495 kg (1,091 lbs)	KQ KQ
	2.3 ℓ M/T with ABS, SRS 2.3 ℓ A/T with ABS, SRS	820 kg (1,808 lbs) / 480 kg (1,058 lbs) 845 kg (1,863 lbs) / 480 kg (1,058 lbs)	KM KM
	2.3 ℓ M/T with ABS, SRS, 4WS 2.3 ℓ A/T with ABS, SRS, 4WS	805 kg (1,775 lbs) / 495 kg (1,091 lbs) 830 kg (1,830 lbs) / 495 kg (1,091 lbs)	KQ KQ
	2.2 ℓ VTEC M/T	810 kg (1,786 lbs) / 505 kg (1,113 lbs)	KQ
	Max. Loaded Vehicle Weight (ADR)	1,653 kg (3,644 lbs)	KQ
	Max. Vehicle Weight (MVW)	1,720 kg (3,792 lbs)	KY

Body Specifications

Unit: mm (in)

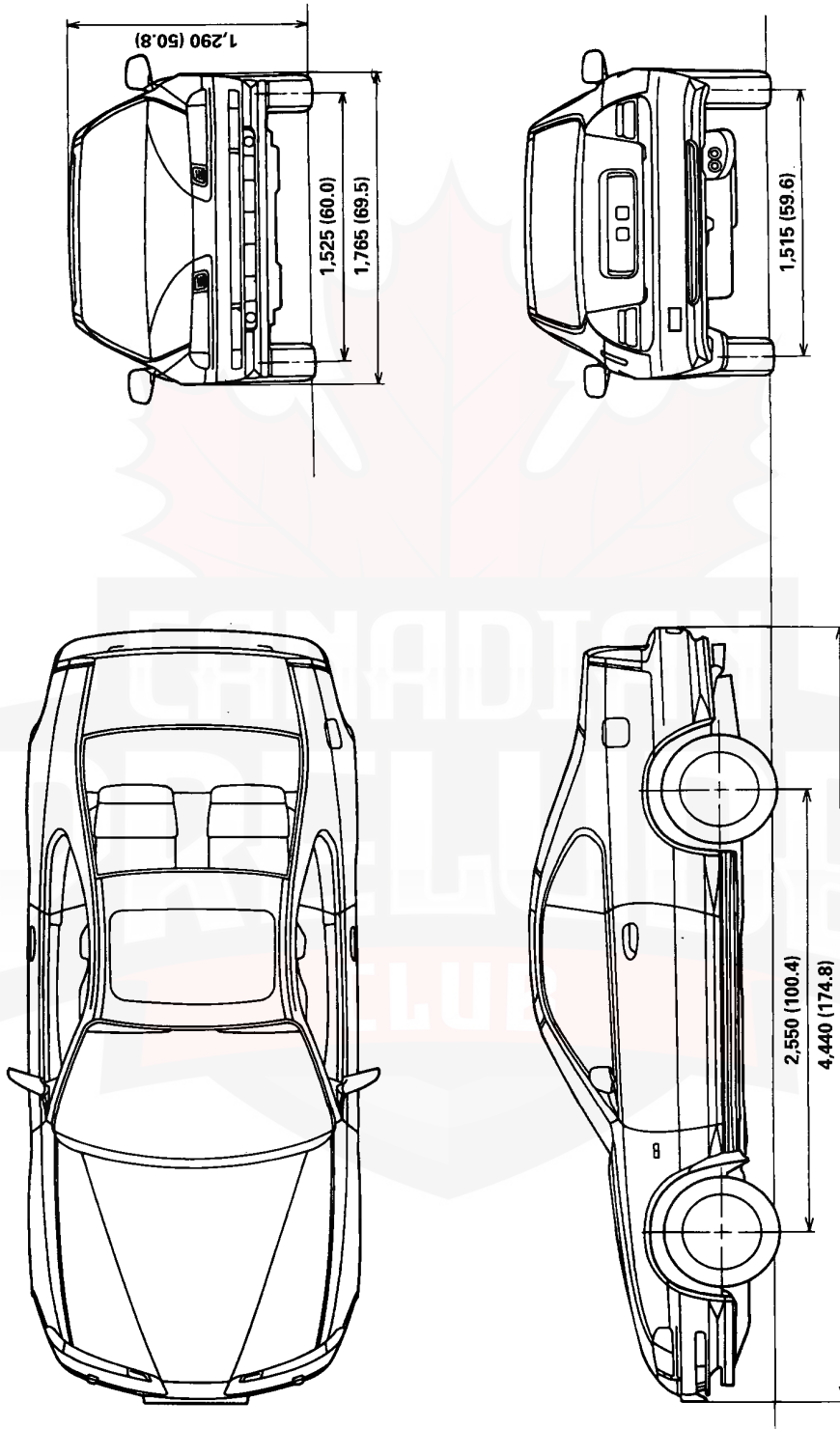

Maintenance

Lubrication Points.....	4-2
Maintenance Schedule.....	4-4

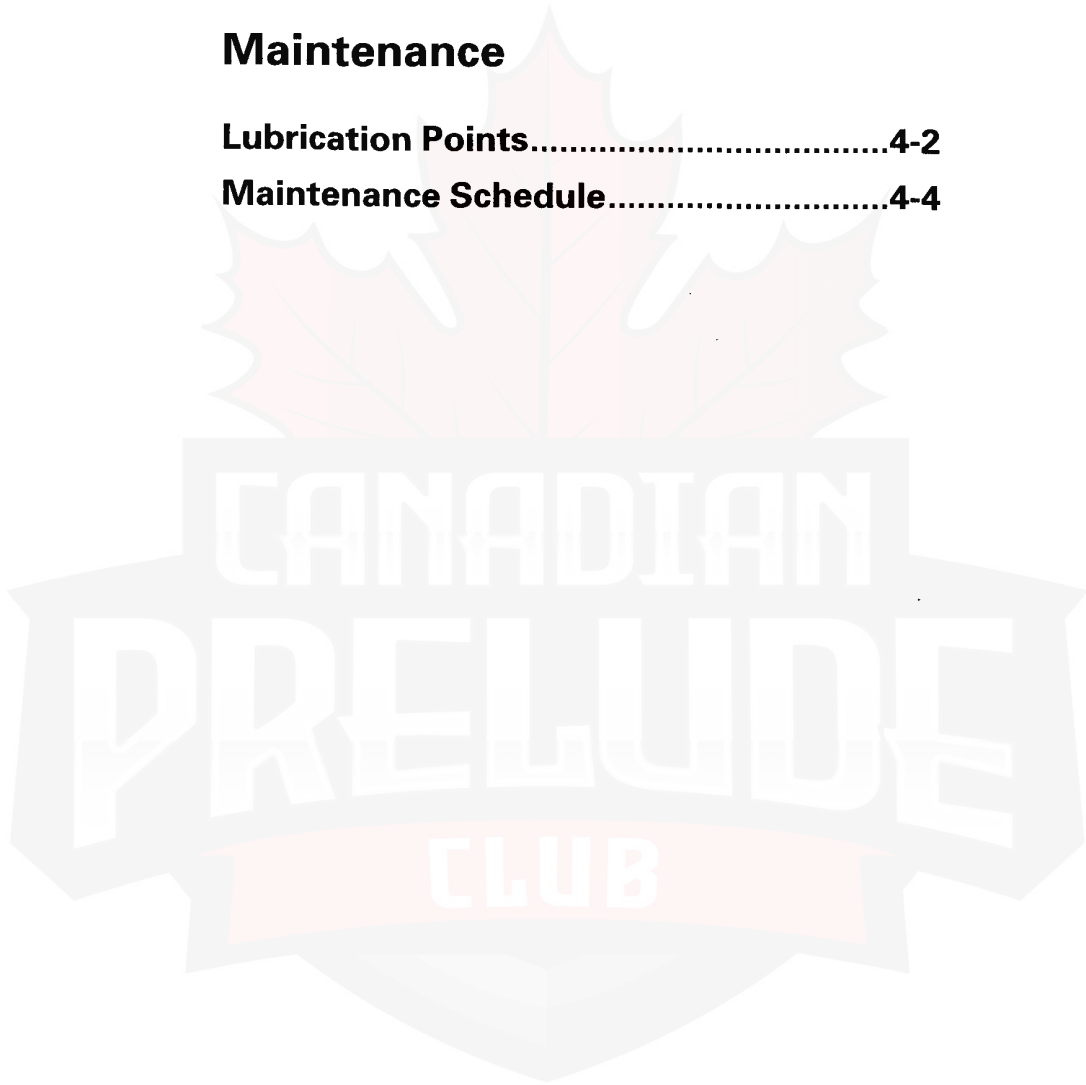

Lubrication Points

For the details of lubrication points and types of lubricants to be applied, refer to the Illustrated Index and various work procedures (such as Assembly/Reassembly, Replacement, Overhaul, Installation, etc.) contained in each section.

No.	LUBRICATION POINTS	LUBRICANT
1	Engine	Always use a fuel-efficient oil is that says "API Service SF, SG or SH." SAE Viscosity: See chart below.
2	Transmission	Manual API Service Grade: SF or SG SAE Viscosity: 10 W-30 or 10 W-40
		Automatic Honda Premium Formula Automatic Transmission Fluid or an equivalent DEXRON® II Automatic transmission fluid
3	Brake Line	Brake fluid DOT3 or DOT4
4	Clutch Line	Brake fluid DOT3 or DOT4
5	Power steering gearbox	Steering grease P/N 08733-B070E
6	Shift lever pivots (Manual transmission)	Grease with molybdenum disulfide
7	Release fork (Manual transmission)	Urea Grease UM264 P/N 41211-PY5-305
8 9 10 11 12 13 14 15 16 17 18 19 20	Steering boots Steering ball joints Select lever (Automatic transmission) Pedal linkage Intermediate shaft Brake master cylinder pushrod Trunk hinges and latches Door hinges upper/lower and latches Door opening detents Fuel filler lid Hood hinges and hood latch Clutch master cylinder pushrod Throttle cable end	Multi-purpose grease
21 22	Caliper Piston seal, Dust seal, Caliper pin, Piston Shift and select cable ends	Silicone grease
23	Power steering system	Honda power steering fluid-V
24	Air conditioning compressor	Compressor oil: SP-10 P/N 38899-P13-003 (For Refrigerant: HFC-134a (R-134a))

Select the oil for the car according to this chart:

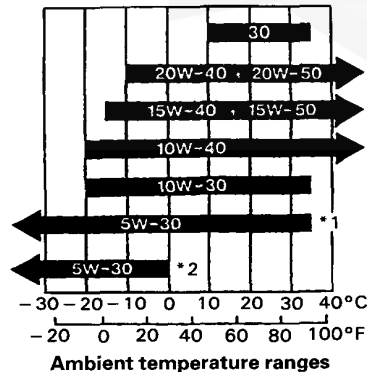

CAUTION:

Used engine oil may causes skin cancer if repeatedly left in contact with the skin for prolonged periods. Although this is unlikely unless you handle used oil on a daily basis, it is still advisable to thoroughly wash your hands with soap and water as soon as possible after handling used oil.

*1: Except cars with H22A1, H22A2 engines.

*2: Cars with H22A1, H22A2 engines

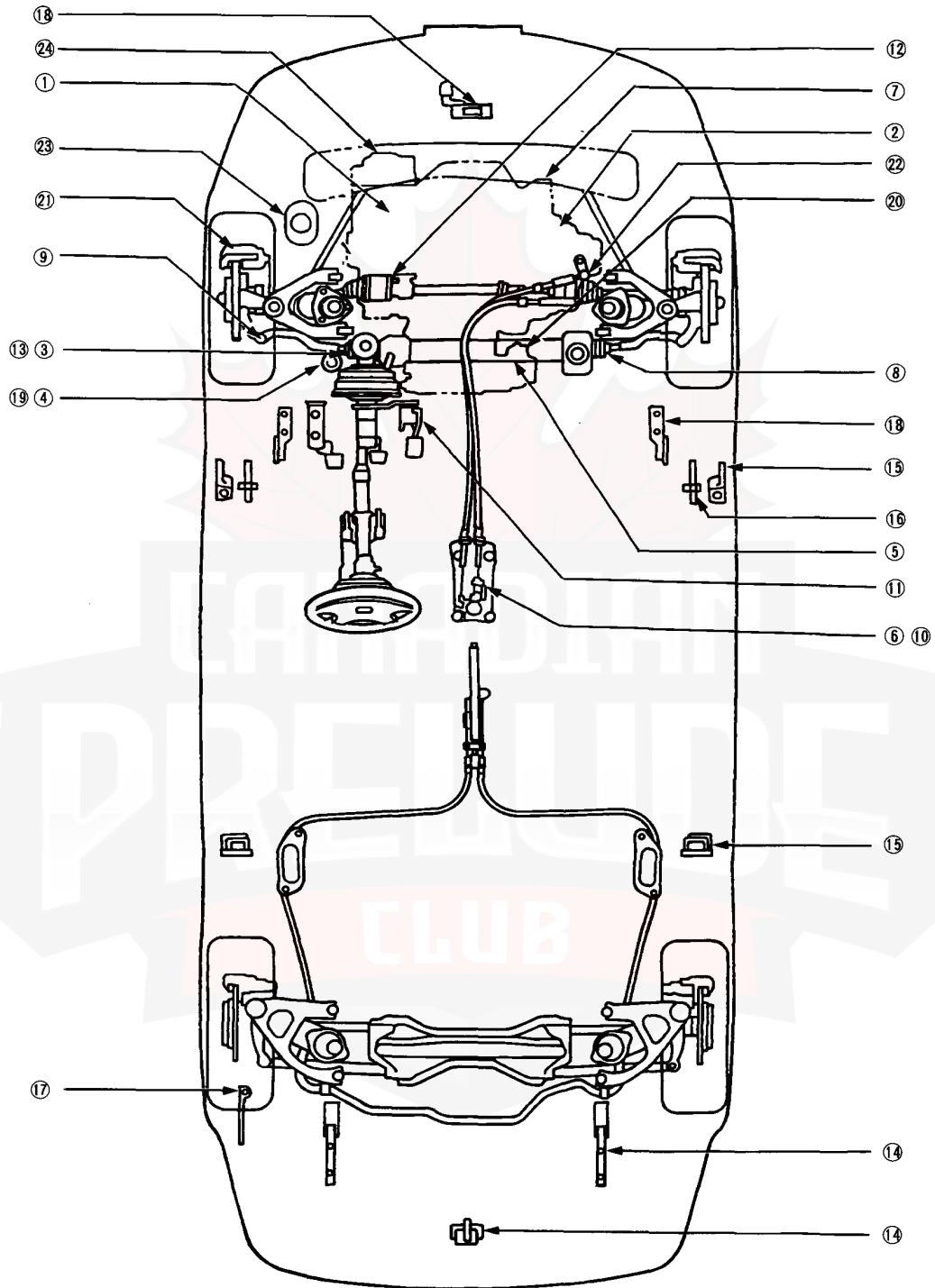

Maintenance Schedule

R=Replace I=Inspect: After inspection, clean, adjust, fill up, repair or replace if necessary.

Service at the interval listed x 1,000 km (or miles) or after that number of months, whichever comes first.		x 1,000 km	20	40	60	80	100	120	140	160	180	200
		x 1,000 miles	12	24	36	48	60	72	84	96	108	120
		months	12	24	36	48	60	72	84	96	108	120
● Engine oil and oil filter	For European models	Replace every 10,000 km (6,000 miles) or 12 months										
	For other than European models	Replace every 10,000 km (6,000 miles) or 6 months										
● Transmission oil	For European models			R			R				R	
	For other than European models		R		R		R		R		R	
Valve clearance	For European models		I		I		I		I		I	
	For other than European models	I	I	I	I	I	I	I	I	I	I	I
Belt tension and conditions (Alternator, Power steering, A/C compressor)			I		I		I		I		I	
Timing belt and timing balancer belt							R					R
Water pump							I					I
Cooling system hoses and connections			I		I		I		I		I	
● Engine coolant						R		R		R		R
Spark plugs	For H22A1, H22A2 engines						R*1					R*1
	Except for H22A1, H22A2 engines	For cars with catalytic converter		R		R		R		R		R
		For KS model, replace every 48,000 km (30,000 miles)										
		For cars without catalytic converter	R	R	R	R	R	R	R	R	R	R
Ignition timing (For other than European models)			I		I		I		I		I	
Air cleaner element	For cars with catalytic converter		R		R		R		R		R	
	For cars without catalytic converter	R	R	R	R	R	R	R	R	R	R	R
Tank, fuel lines and connections			I		I		I		I		I	
Fuel filter			R		R		R		R		R	
Positive crankcase ventilation valve							I					I
Idle speed and idle CO		I*2	I*2	I*2	I*2	I	I	I	I	I	I	I

●: Day to day care (engine oil, ATF and coolant level) should be done practically according to the owner's manual by the customer.

*1: Replace every 6 years or 100,000 km (60,000 miles), whichever comes first.

*2: For KS model, recommended by manufacturer only: except for KS model, it is required.



R=Replace I=Inspect: After inspection, clean, adjust, fill up, repair or replace if necessary.

Service at the interval listed x 1,000 km (or miles) or after that number of months, whichever comes first.	x 1,000 km	20	40	60	80	100	120	140	160	180	200
	x 1,000 miles	12	24	36	48	60	72	84	96	108	120
	months	12	24	36	48	60	72	84	96	108	120
Evaporative emission control system (For other than European models)						I					I
Distributor cap and rotor (For other than European models)		I		I			I		I		I
Ignition wiring (For other than European models)		I		I			I		I		I
Front brake pads	Inspect every 10,000 km (6,000 miles) or 12 months										
Front brake discs and calipers	I	I	I	I	I	I	I	I	I	I	I
Rear brake discs, calipers and pads		I		I			I		I		I
Parking brake operation	I	I		I			I		I		I
Brake fluid (Including ABS)		R		R			R		R		R
Brake hoses and lines	I	I	I	I	I	I	I	I	I	I	I
Anti-lock brake system operation (For cars with ABS)	I	I		I			I		I		I
Anti-lock brake system high pressure hose (For cars with ABS)				R					R		
Exhaust system and condition	I	I	I	I	I	I	I	I	I	I	I
Catalytic converter heat shield (For cars with catalytic converter)						I					I
Suspension components	I	I	I	I	I	I	I	I	I	I	I
Steering function, tie-rod ends, gear box and boots (Including rear actuator for 4WS model)	Except for 4WS model	I	I		I		I		I		I
	For 4WS model	I	I	I	I	I	I	I	I	I	I
Power steering function, hoses and connections	I	I	I	I	I	I	I	I	I	I	I
All fluid levels	Inspect every 10,000 km (6,000 miles) or 12 months										
Battery condition	I	I	I	I	I	I	I	I	I	I	I
Tyres condition, wear and pressure (Including spare)	Inspect every 10,000 km (6,000 miles) or 12 months										
Lights operation and headlight beam	Inspect every 10,000 km (6,000 miles) or 12 months										
Paint damages and body work	I	I	I	I	I	I	I	I	I	I	I
Test drive (Noise, stability, dashboard operations)	I	I	I	I	I	I	I	I	I	I	I
Cleanlines of controls, door handles etc.	Inspect after every Service										
Supplemental Restraint System	Inspect system and replace slip ring ^{*3} 10 years after first registration.										

^{*3}: Except for cars with passenger's airbag

(cont'd)

Maintenance Schedule

(cont'd)

Severe Driving Conditions

The following items must be serviced more frequently on cars normally used under severe driving conditions. Refer to the chart below for the appropriate maintenance intervals.

Severe driving conditions include:

- A: Repeated short distance driving.
- B: Driving in dusty conditions.
- C: Driving in severe cold weather.
- D: Driving in areas using road salt or other corrosive materials.
- E: Driving on rough and/or muddy roads.
- F: Towing a trailer.

R=Replace C=Clean I=Inspect: After inspection, clean, adjust, fill up, repair or replace if necessary.

Condition	Maintenance		Operation	Interval
A B . . . F	Engine oil and oil filter	For European models	R	Every 5,000 km (3,000 miles) or 6 months
		For other than European models	R	Every 5,000 km (3,000 miles) or 3 months
. F	Transmission oil		R	Every 20,000 km (12,000 miles) or 12 months
. B . . E .	Air cleaner element	For cars with catalytic converter	C	Every 20,000 km (12,000 miles) or 12 months
			R	Every 40,000 km (24,000 miles) or 24 months
		For cars without catalytic converter	C	Every 10,000 km (6,000 miles) or 6 months
			R	Every 20,000 km (12,000 miles) or 12 months
A B . D E F	Front brake discs and calipers		I	Every 10,000 km (6,000 miles) or 6 months
A B . D E F	Rear brake discs, calipers and pads		I	Every 20,000 km (12,000 miles) or 12 months
. B C . E .	Power steering system		I	Every 10,000 km (6,000 miles) or 6 months

Fuel and Emissions

Troubleshooting

Self-diagnostic Procedures

(H23A1 engine KM model).....11-2

Idle Control System

Idle Speed Setting

(H23A1 engine KM model).....11-3

Emission Control System

System Description

(H23A1 engine KM model).....11-4

Tailpipe Emission

(H23A1 engine KM model).....11-4



Outline of Model Changes

- H23A1 engine has been added for KM model, refer to base Shop Manuals H23A1 engine (P/N: 62SS000, 62SS020, 62SS021) and changed following:
 - Self-diagnostic Procedures
 - Idle Speed Setting
 - Emission Control System

Troubleshooting

Self-diagnostic Procedures (H23A1 engine KM model)

When the Check Engine Light has been reported on, refer to base Shop Manual (P/N: 62SS000) and blink the code.

SELF-DIAGNOSIS INDICATOR BLINKS	SYSTEM INDICATED
0	ECU
1	OXYGEN SENSOR
3	MANIFOLD ABSOLUTE PRESSURE (MAP) SENSOR
5	
4	CRANK ANGLE (CRANK) SENSOR
6	COOLANT TEMPERATURE (TW) SENSOR
7	THROTTLE ANGLE SENSOR
8	TDC POSITION (TDC) SENSOR
9	No. 1 CYLINDER POSITION (CYL) SENSOR
10	INTAKE AIR TEMPERATURE (TA) SENSOR
12	EXHAUST GAS RECIRCULATION (EGR) SYSTEM
13	ATMOSPHERIC PRESSURE (PA) SENSOR
14	ELECTRONIC AIR CONTROL VALVE (EACV)
15	IGNITION OUTPUT SIGNAL
17	VEHICLE SPEED SENSOR
20	ELECTRICAL LOAD DETECTOR (ELD)
23	KNOCK SENSOR
30	A/T FI SIGNAL A
31	A/T FI SIGNAL B
41	OXYGEN SENSOR HEATER

- For respective the code, refer to base Shop Manuals (P/N: 62SS000, 62SS020, 62SS021).
- If codes other than those listed above are indicated, verify the code. If the code indicated is not listed above, replace the ECU.
- The Check Engine Light may come on, indicating a system problem when, in fact, there is a poor or intermittent electrical connection. First, check the electrical connections, clean or repair connections if necessary.
- The Check Engine Light and **[S]** light may light simultaneously when the self-diagnosis indicator blinks 6, 7 and 17. Check the PGM-FI system according to the PGM-FI control system troubleshooting, then recheck the **[S]** light.
- The Check Engine Light does not come on when there is a malfunction in the A/T FI signal or Electrical Load Detector circuits. However, it will indicate the codes when the Service Check Connector is jumped.



Idle Control System

Idle Speed Setting (H23A1 engine KM model)

Inspection/Adjustment

NOTE:

- When the idle Speed set, check the following items:
 - The Check Engine Light has not been reported on.
 - Ignition timing
 - Spark plugs
 - Air cleaner
 - PCV system

1. Connect a tachometer.
2. Start the engine. Hold the engine at 3,000 rpm (min^{-1}) with no load (A/T in **N** or **P** position, M/T in neutral) until the radiator fan comes on, then let it idle.
3. Disconnect the 2P connector from the EACV.

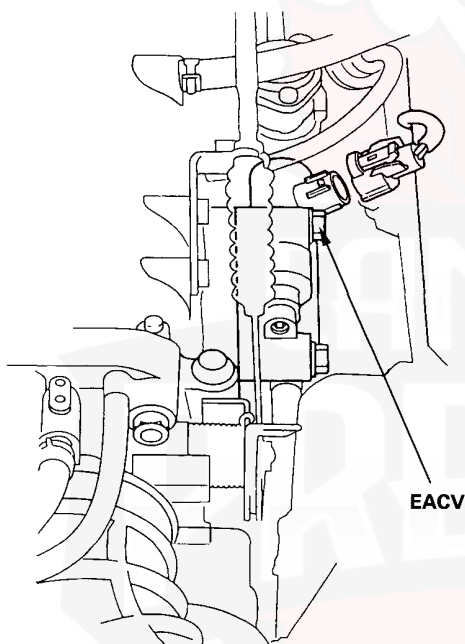

4. Start the engine with the accelerator pedal slightly depressed. Stabilize the engine speed at 1,000, then slowly release the pedal until the engine idles.
5. Check idling in no-load conditions: headlights, blower fan, rear defogger, cooling fan, and air conditioner are not operating.

Idle speed should be:

M/T	550 ± 50 rpm (min^{-1})
A/T	550 ± 50 rpm (min^{-1}) (in N or P position)

Adjust the idle speed, if necessary, by turning the idle adjusting screw.

NOTE:

After adjusting the idle speed in this step, recheck the ignition timing (see section 23).
If it is out of spec, go back to step 4.

IDLE ADJUSTING SCREW

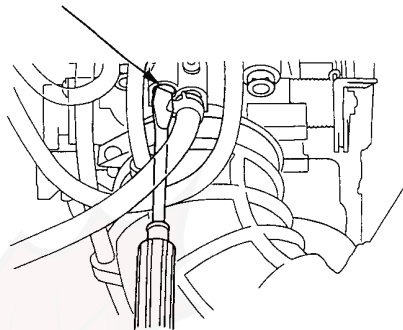

6. Turn the ignition switch OFF.
7. Reconnect the 2P connector on the EACV, then remove CLOCK RADIO (10 A) fuse in the underhood fuse/relay box for 10 seconds to reset the ECU.
8. Restart and idle the engine with no-load conditions for one minute, then check the idle speed.

Idle speed should be:

M/T	700 ± 50 rpm (min^{-1})
A/T	700 ± 50 rpm (min^{-1}) (in N or P position)

9. Idle the engine for one minute with headlights (Low) ON and check the idle speed.

Idle speed should be:

M/T	780 ± 50 rpm (min^{-1})
A/T	780 ± 50 rpm (min^{-1}) (in N or P position)

10. Turn the headlights off. Idle the engine for one minute with heater fan switch at HI and air conditioner on, then check the idle speed.

Idle speed should be:

M/T	780 ± 50 rpm (min^{-1})
A/T	780 ± 50 rpm (min^{-1}) (in N or P position)

NOTE:

If the idle speed is not within specification, see System Troubleshooting Guide.

Emission Control System

System Description (H23A1 engine KM model)

The emission control system includes a three-way catalytic converter, exhaust gas recirculation (EGR) system, crankcase ventilation system and evaporative control system.

Tailpipe Emission (H23A1 engine KM model)

Inspection

▲WARNING

Do not smoke during this procedure. Keep any open flame away from your work area.

1. Connect a tachometer.
2. Start the engine. Hold the engine at 3,000 rpm (min^{-1}) with no load (A/T in **[N]** or **[P]** position, M/T in neutral) until the radiator fan comes on, then let it idle.
3. Check and adjust the idle speed, if necessary (see page 11-3).
4. Warm up and calibrate the CO meter according to the meter manufacturer's instructions.
5. Check idle CO with the headlights, heater blower, rear window defogger, cooling fan, and air conditioner off.

CO meter should indicate 0.1% maximum.

Transaxle

Manual Transmission.....13-1

Automatic Transmission.....14-1

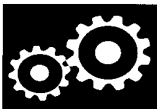
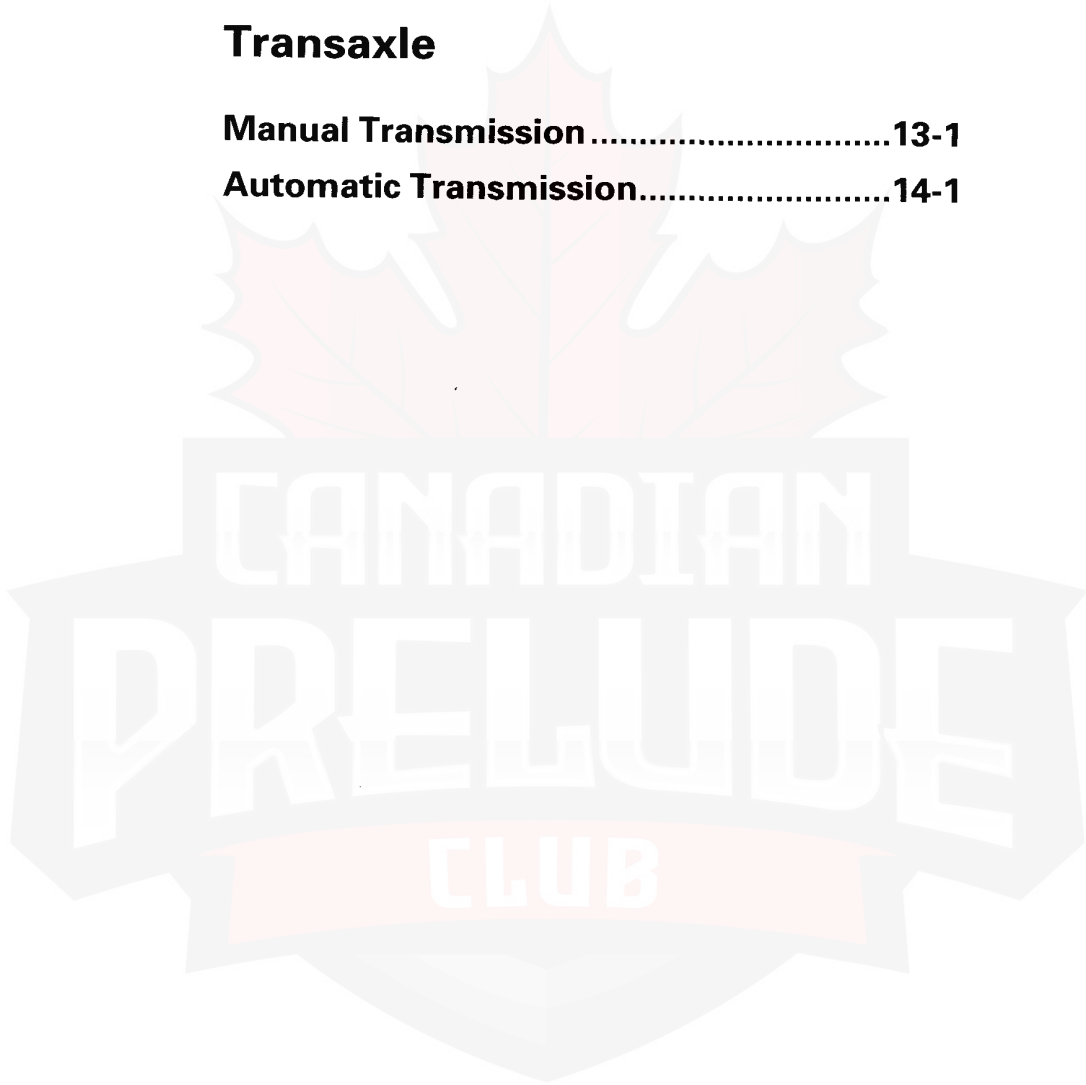

Manual Transmission

Countershaft

Clearance Inspection13-2

Transmission

Reassembly.....13-3

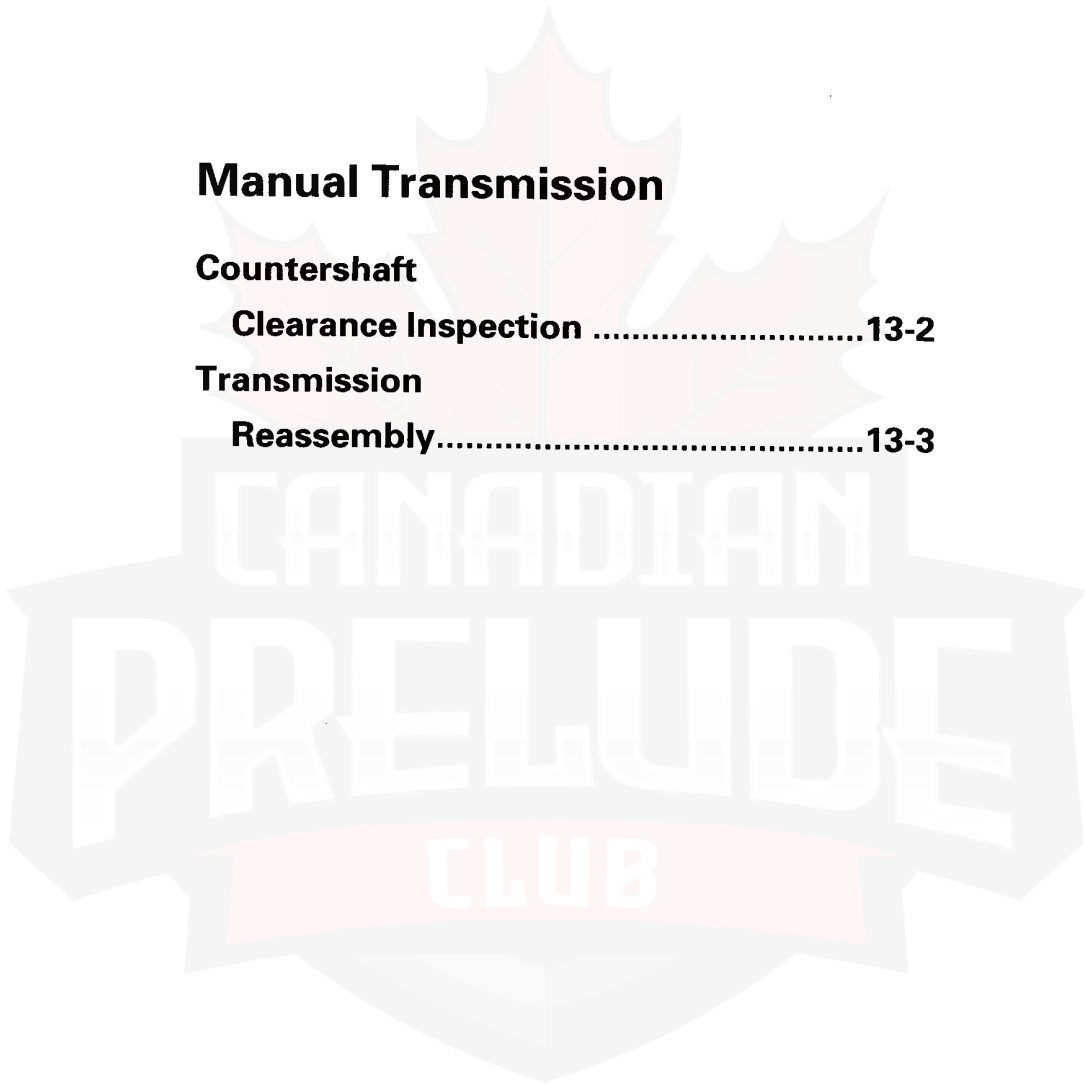

Outline of Model Changes

- Countershaft clearance inspection has been changed.
- Reverse idler gear shaft bolt torque has been changed.

Countershaft

Clearance Inspection

1. Measure the clearance between the 1st gear and thrust washer.

Standard : 0.06 – 0.23 mm
(0.002 – 0.009 in)
Service Limit : 0.23 mm (0.009 in)

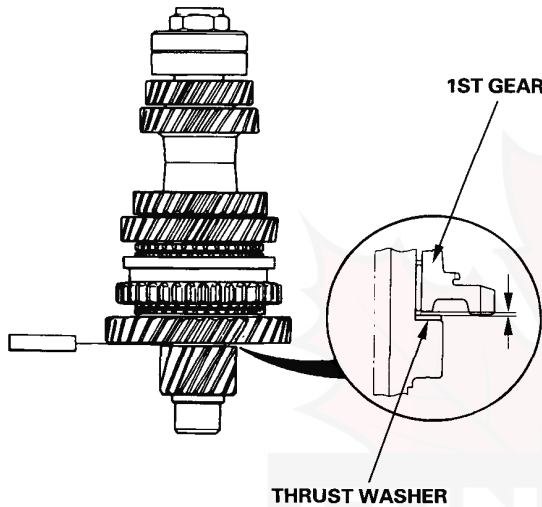

2. If the clearance exceeds the service limit, measure the thicknesses of 1st gear and thrust washer.

1ST GEAR
Standard : 32.95 – 33.00 mm (1.297 – 1.299 in)

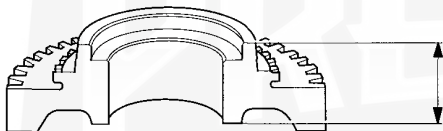

THRUST WASHER
Standard : 1.95 – 1.97 mm (0.077 – 0.078 in)



- If the thicknesses of 1st gear and thrust washer are less than the standard, replace with a new one.
- If the thicknesses of 1st gear and thrust washer are within the standard, replace the 1st/2nd synchro hub with a new one.

3. Measure the clearance between the 2nd gear and 3rd gear.

Standard : 0.05 – 0.10 mm
(0.002 – 0.004 in)
Service Limit : 0.18 mm (0.007 in)

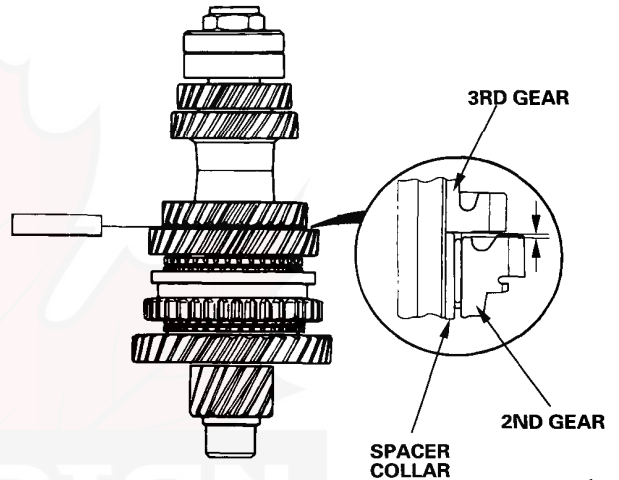

4. If the clearance exceeds the service limit, measure the thicknesses of 2nd gear and spacer collar.

2ND GEAR
Standard : 28.92 – 28.97 mm (1.139 – 1.141 in)

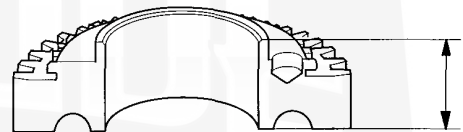

SPACER COLLAR
Standard : 29.02 – 29.04 mm (1.1425 – 1.1433 in)

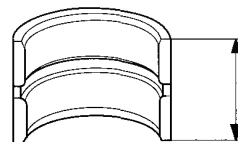

- If the thicknesses of 2nd gear and spacer collar are less than the standard, replace with a new one.
- If the thicknesses of 2nd gear and spacer collar are within the standard, replace the 1st/2nd synchro hub with a new one.



Transmission

Reassembly

Torque the reverse idler gear shaft bolt as shown.

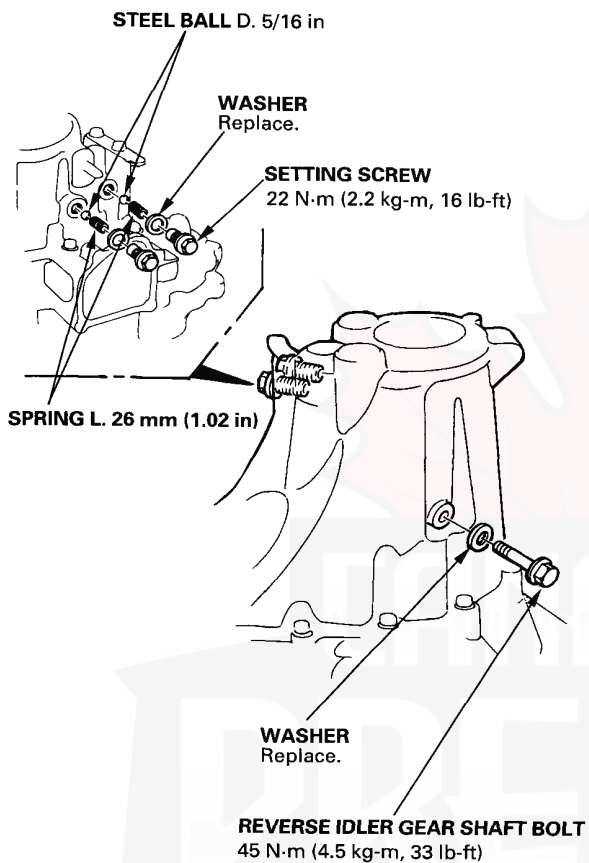

SUPPLEMENTAL RESTRAINT SYSTEM (SRS)

(If automatic transmission maintenance is required)

Some versions of the KE, KG, KF, KS Prelude models and the KM model include a driver's airbag, located in the steering wheel hub, and a front passenger's airbag, located in the dashboard above the glove box. The SRS unit of these model versions is not part of the airbag assembly and has built-in sensors (SRS Type III). Some other KE, KG, KF, KS model versions and the KQ model include only a driver's airbag, located in the steering wheel hub. The SRS unit of these model versions is part of the airbag assembly (SRS Type II). Information necessary to safely service the SRS is included in the Shop Manual Supplement 62SS020 (SRS Type II) and in the Shop Manual Supplement 62SS021 (SRS Type III). Items marked with an asterisk (*) on the contents page include, or are located near, SRS components.

Servicing, disassembling or replacing these items will require special precautions and tools, and should therefore be done by an authorized Honda dealer.

▲WARNING

- To avoid rendering the SRS inoperative, which could lead to personal injury or death in the event of a severe frontal collision, all SRS service work must be performed by an authorized Honda dealer.
- Improper service procedures, including incorrect removal and installation of the SRS, could lead to personal injury caused by unintentional activation of the airbag(s).
- Do not bump the SRS unit. Otherwise, the system may fail in case of a collision, or the airbags may deploy when the ignition switch is ON (II) (SRS Type III).
- All SRS electrical wiring harnesses are covered with yellow insulation. Related components are located in the steering column, front console, dashboard, dashboard lower panel, and, in case of some models, in the dashboard above the glove box. Do not use electrical test equipment on these circuits.
- Service work nearby and in the areas listed below may affect the SRS and must therefore be performed by an authorized Honda dealer.

SRS Type II:

- Steering wheel (Be careful not to bump the steering wheel as the SRS unit (sensors), inflator, etc. are located in it.)
- Behind the dashboard
- Under-dash fuse/relay box

SRS Type III:

- Steering wheel
- Behind the dashboard
- Under-dash fuse/relay box
- Front console
- Car stereo unit and other accessories
- A/C heater

Automatic Transmission

Clutch

Illustrated Index14-2

Secondary Shaft

Inspection.....14-4

Transmission

Installation14-5

* Shift Lever (KM model)14-6

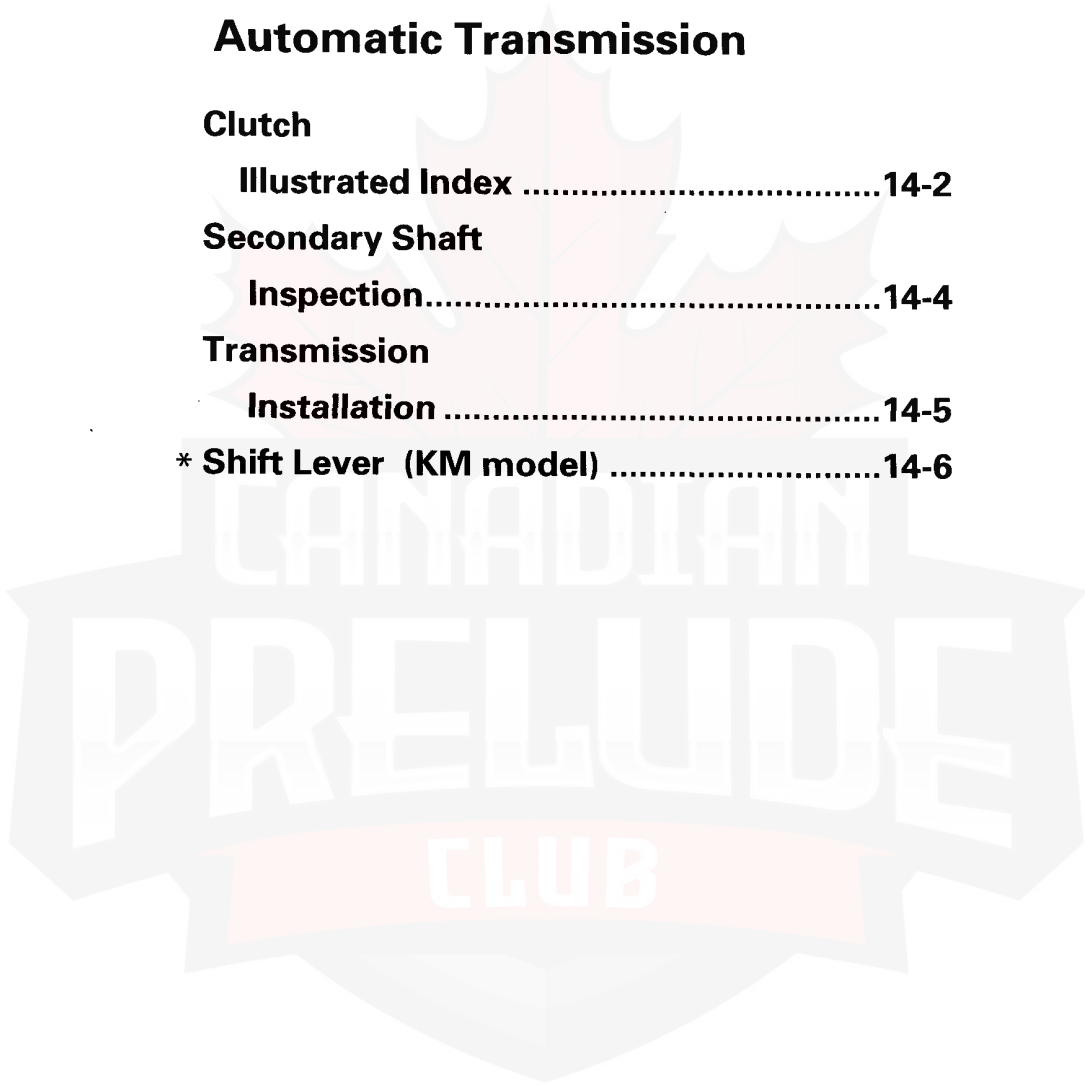

Outline of Model Changes

- New 1st clutch discs have been added.
- 1st-hold clutch plates have been changed.
- Secondary shaft axial clearance specification has been changed.
- Torque value of the transmission housing bolts has been changed.
- Parking pin switch for KM model has been added.

Clutch

Illustrated Index

1ST/2ND CLUTCH ASSEMBLY: F20A4/F22A1/F22A2 Engines

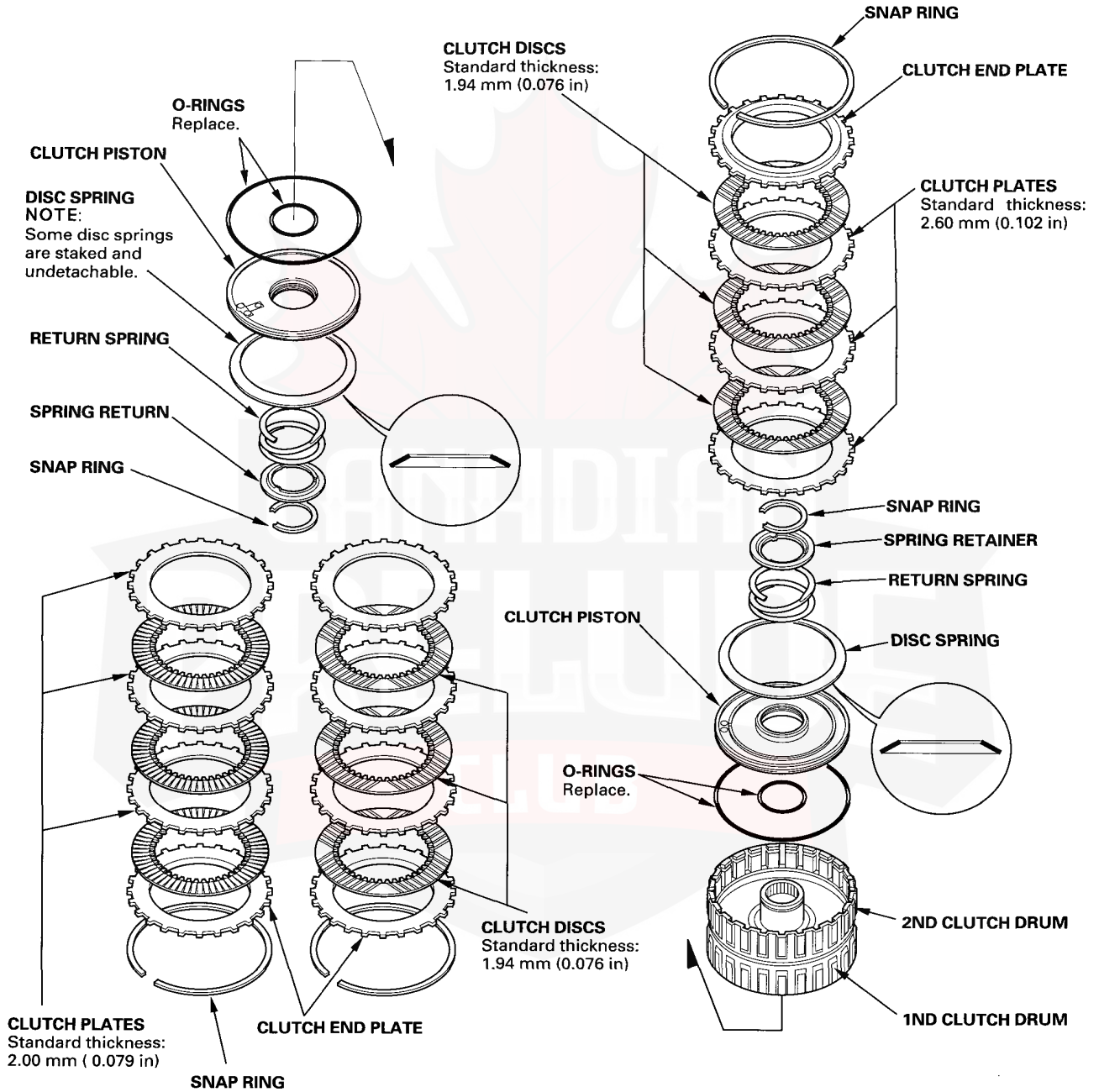

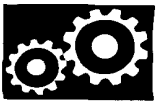

1ST-HOLD CLUTCH ASSEMBLY: F20A4/ F22A1/ F22A2/ H23A1/H23A2 Engines

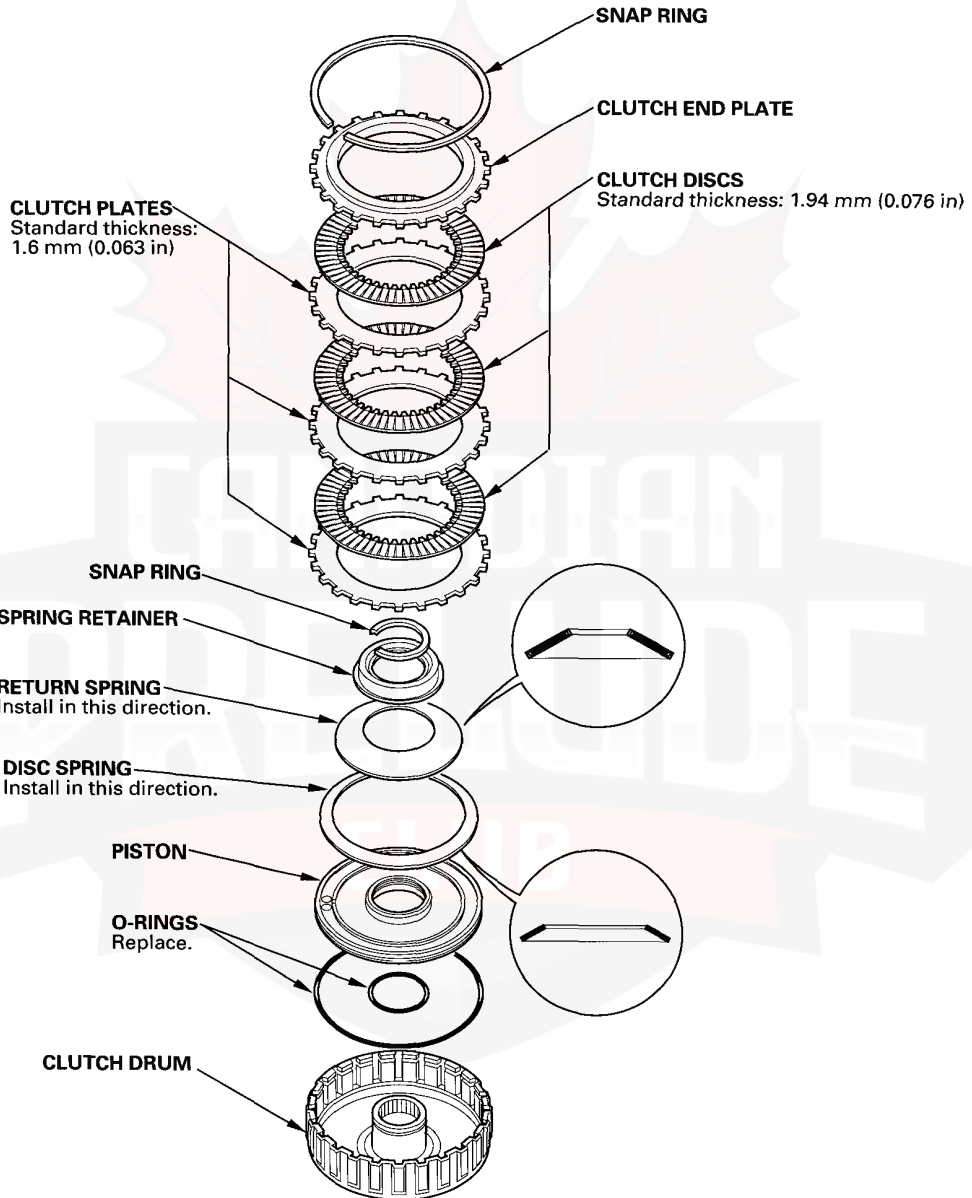

Secondary Shaft

Inspection

• Clearance Measurement

NOTE: Lubricate all parts with ATF during assembly.

1. Remove the secondary shaft bearing from the transmission housing (see Base Manual on page 14-146).
2. Assemble the secondary shaft assembly without O-rings.
3. Install the secondary shaft bearing on the secondary shaft.

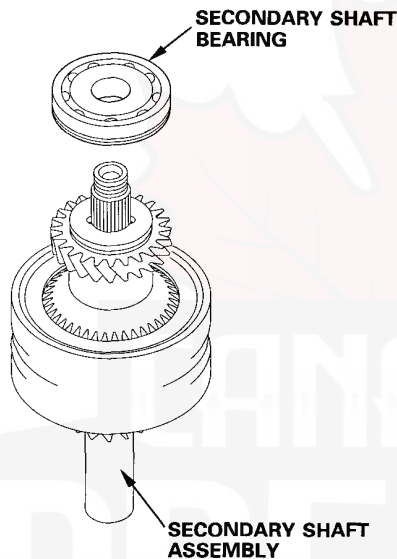

4. Set the dial indicator to the 2nd gear as shown.

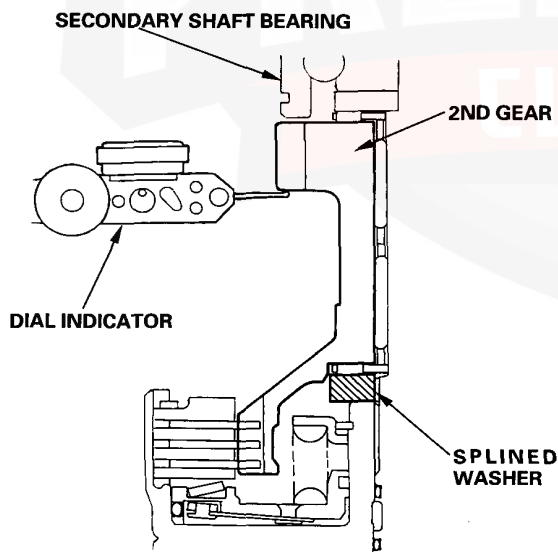

5. Hold the secondary shaft bearing against 1st/2nd clutch assembly. Measure the 2nd gear axial clearance while moving the 2nd gear.

STANDARD: 0.04 – 0.12 mm (0.002 – 0.005 in)

NOTE:

Take measurements in at least three places, and use the average as the actual clearance.

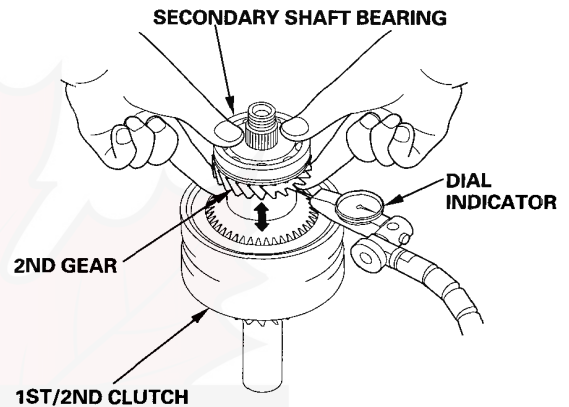

6. If the clearance is out of tolerance, remove the splined washer and measure its thickness.
7. Select and install a new splined washer then recheck.

SPLINED WASHER

No.	Part Number	Thickness
1	90406-PX4-700	4.05 mm (0.159 in)
2	90407-PX4-700	4.10 mm (0.161 in)
3	90408-PX4-700	4.15 mm (0.163 in)
4	90409-PX4-700	4.20 mm (0.165 in)
5	90410-PX4-700	4.25 mm (0.167 in)
6	90411-PX4-700	4.30 mm (0.169 in)
7	90412-PX4-700	4.35 mm (0.171 in)
8	90413-PX4-700	4.40 mm (0.173 in)
9	90414-PX4-700	4.45 mm (0.175 in)

8. After replacing the splined washer, make sure that the clearance is within tolerance.

Transmission



Installation

NOTE:

- The torque value of the transmission housing mounting bolts have been changed.
 - These procedures shown are the exceptions from Transmission Installation of Base Manual (62SS021) on page 14-25.
 - Refer to these procedures and Transmission Installation of Base Manual, when you install the transmission.
25. Place the transmission housing on the torque converter housing.

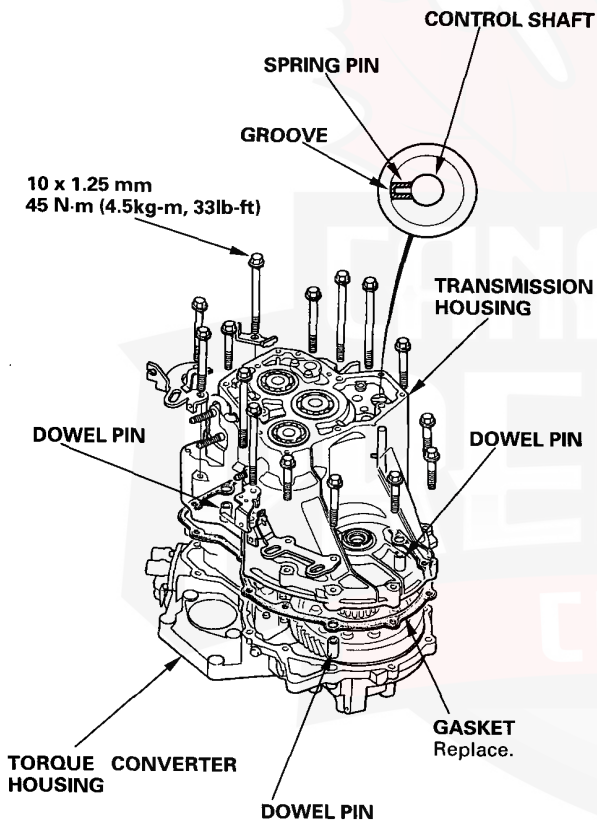

26. Install the transmission housing bolts along with the transmission hanger, throttle control cable stay/ transmission hanger and harness stay. Torque the bolts in two or more steps in the sequence shown.

TORQUE: 45 N·m (4.5 kg-m, 33 lb-ft)

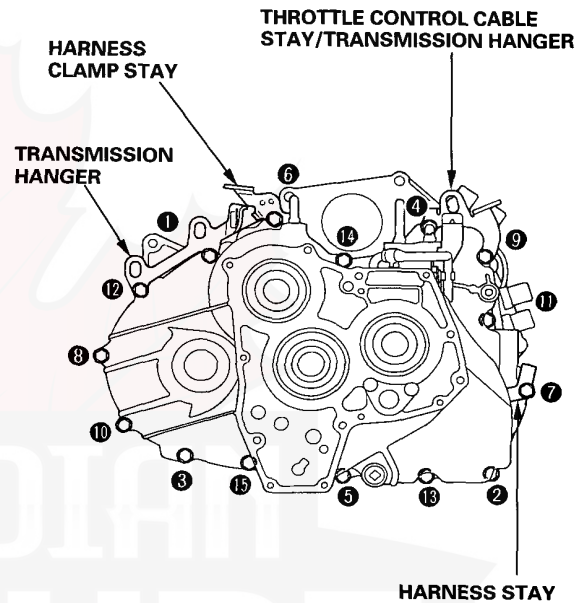

Shift Lever (KM model)

CAUTION:

- All SRS wire harnesses are covered with yellow insulation.
- Replace the entire affected SRS harness assembly if it has an open circuit or damaged wiring.
- Before disconnecting the SRS wire harness, turn the ignition switch OFF, disconnect the battery negative cable, then disconnect the positive cable, and wait at least three minutes.
- Whenever the ignition switch is ON (II), or has been turned OFF for less than three minutes, be careful not to bump the SRS unit; the airbags could accidentally deploy and cause damage or injuries.
- Before you disconnect any part of an SRS wire harness, connect the short connectors (RED) to the airbags (SRS type III).
- For additional precautions, refer to the Shop Manual Supplement 62SS020 (SRS type II) or 62SS021 (SRS type III).

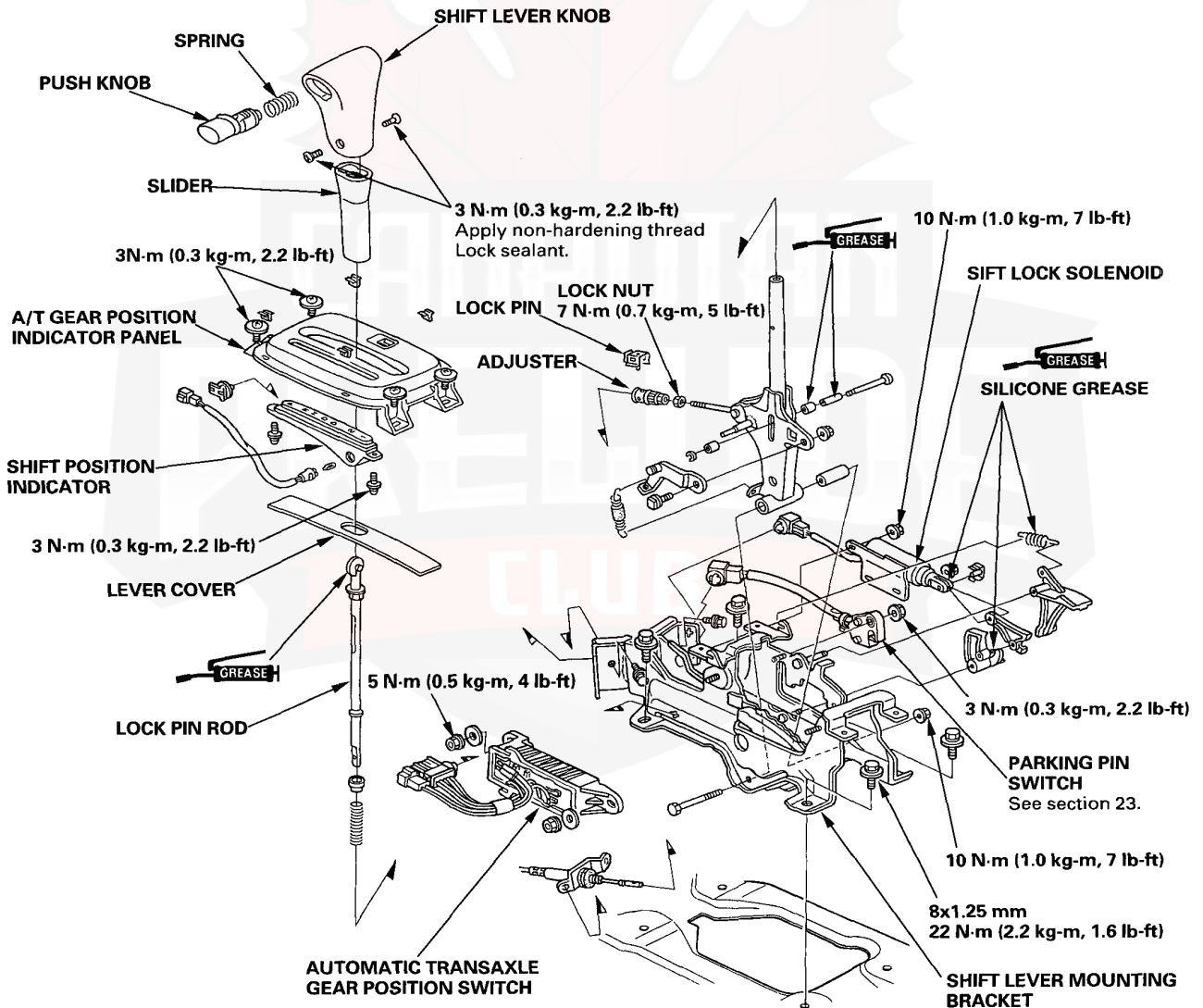
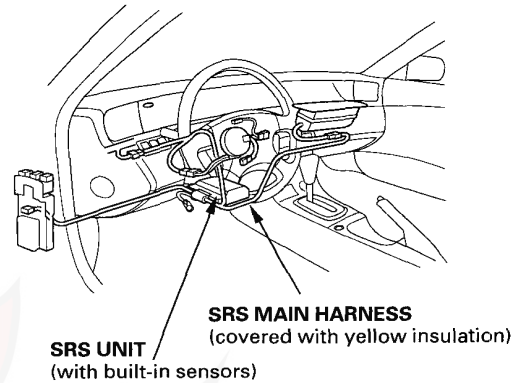

SUPPLEMENTAL RESTRAINT SYSTEM (SRS) (If body maintenance is required)

Some versions of the KE,KG,KF,KS Prelude models and the KM model include a driver's airbag, located in the steering wheel hub, and a front passenger's airbag, located in the dashboard above the glove box. The SRS unit of these model versions is not part of the airbag assembly and has built-in sensors (SRS Type III). Some other KE,KG,KF,KS model versions and the KQ model include only a driver's airbag, located in the steering wheel hub. The SRS unit of these model versions is part of the airbag assembly (SRS Type II). Information necessary to safely service the SRS is included in the Shop Manual Supplement 62SS020 (SRS Type II) and in the Shop Manual Supplement 62SS021 (SRS Type III). Items marked with an asterisk (*) on the contents page include, or are located near, SRS components. Servicing, disassembling or replacing these items will require special precautions and tools, and should therefore be done by an authorized Honda dealer.

▲ WARNING

- **To avoid rendering the SRS inoperative, which could lead to personal injury or death in the event of a severe frontal collision, all SRS service work must be performed by an authorized Honda dealer.**
- **Improper service procedures, including incorrect removal and installation of the SRS, could lead to personal injury caused by unintentional activation of the airbag(s).**
- **Do not bump the SRS unit. Otherwise, the system may fail in case of a collision, or the airbags may deploy when the ignition switch is ON (II) (SRS Type III).**
- **All SRS electrical wiring harnesses are covered with yellow insulation. Related components are located in the steering column, front console, dashboard, dashboard lower panel, and, in case of some models, in the dashboard above the glove box. Do not use electrical test equipment on these circuits.**
- **Service work nearby and in the areas listed below may affect the SRS and must therefore be performed by an authorized Honda dealer.**

SRS Type II:

- Steering wheel (Be careful not to bump the steering wheel as the SRS unit (sensors), inflator, etc. are located in it.)
- Behind the dashboard
- Under-dash fuse/relay box

SRS Type III:

- Steering wheel
- Behind the dashboard
- Under-dash fuse/relay box
- Front console
- Car stereo unit and other accessories
- A/C heater

Body

* Dashboard

Component Removal/Installation20-4

Door

Outer Handle Replacement20-2

License Plate Trim

Replacement20-5

Seat Belt

Upper and Lower Anchor Bolt

Construction20-4

Side Sill Panel

Replacement20-5

Sunroof

Seal Holder Removal/Installation20-3

NOTE:

Refer to the 1992 Prelude Shop Manual, P/N 62SS000, and the 1994 Prelude Shop Manual Supplement, P/N 62SS021, for the items not shown in this section.

Outline of Model Changes

- The knee bolster has been added (KM model).
- The door cylinder protector has been added.
- The license plate trim replacement procedure has been added (for some models).
- The front seat belt upper and lower anchor bolt construction has been changed.
- The front seat belt is added with a TAKATA made.
- The quantities of the side sill panel clips used have been changed.
- The sunroof seal holder mounting nuts have been changed.



Door

Outer Handle Replacement

NOTE:

Raise the glass fully.

1. Remove:
 - Door panel
 - Plastic cover
2. Remove the rod protector.

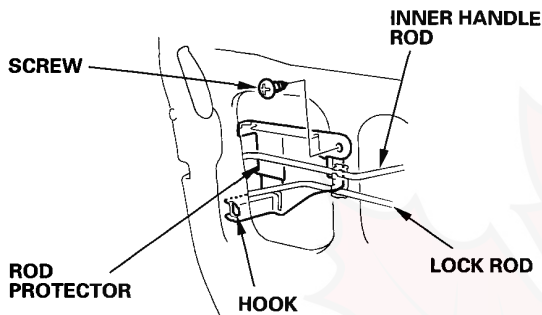

3. Peel off the access hole seal.
4. Remove the mounting bolts and clip, then pull the outer handle out.

CAUTION:

Use protective tape around the outer handle to prevent damage.

NOTE:

Do not drop the mounting bolts and clip inside the door.

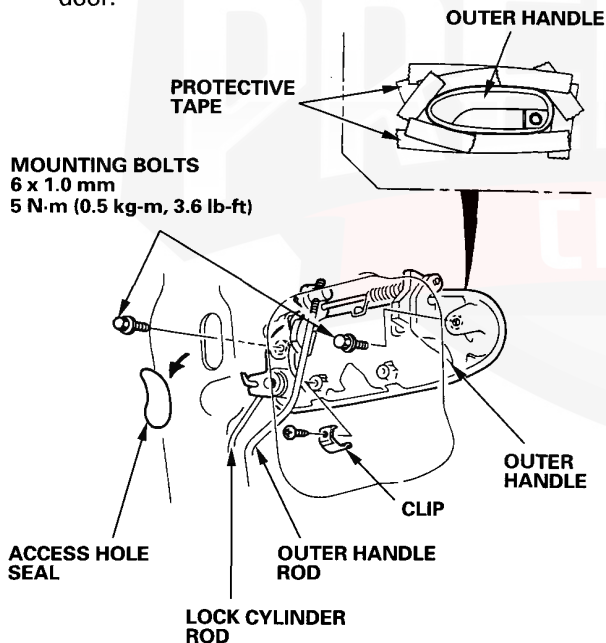

5. Pull out the outer handle.
Pry the outer handle rod out of its joint using diagonal cutters.

NOTE:

- To ease reassembly, note location Ⓐ of the outer handle rod the joint before disconnecting it.
- Take care not to bend the outer handle rod.

6. Disconnect the lock cylinder rod as shown, then remove the outer handle.

NOTE:

Take care not to damage the lock cylinder joint.

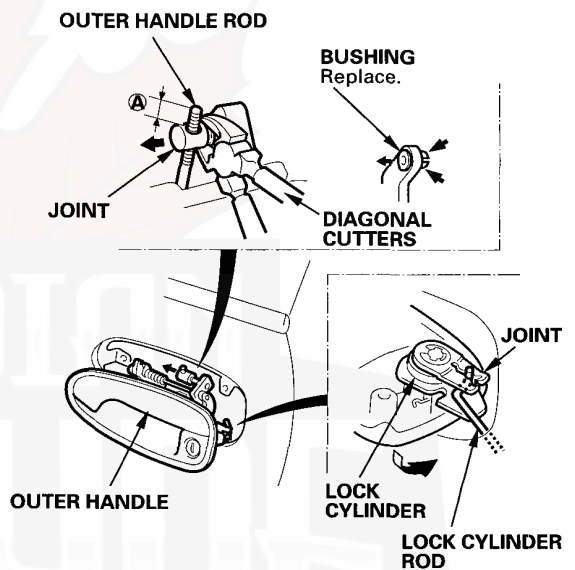

7. If necessary, remove the lock cylinder, cylinder protector and cap.
Pry the retainer clip with a plier as shown.

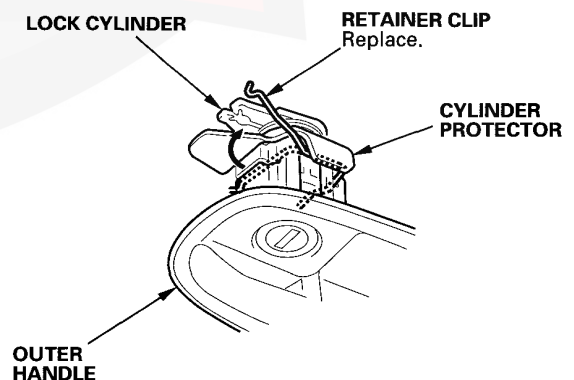



Sunroof

Seal Holder Removal/Installation

8. Release the retainer clip with a plier from the outer handle as shown.

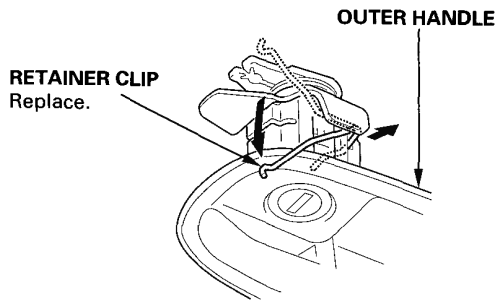

9. Remove the lock cylinder, cylinder protector and cap from the outer handle.

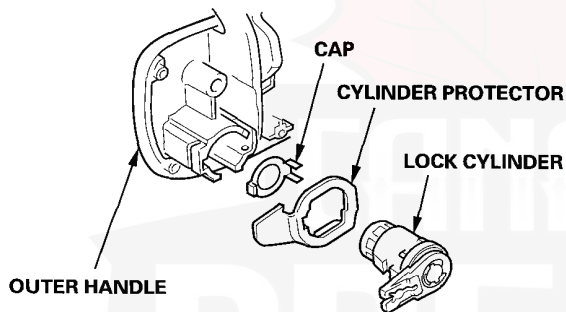

10. Installation is the reverse of the removal procedure.

NOTE:

- Before installing the cylinder protector and lock cylinder, install the new retainer clip on the outer handle.
- Make sure the outer handle rod is connected securely.
- Make sure the door locks and opens properly.

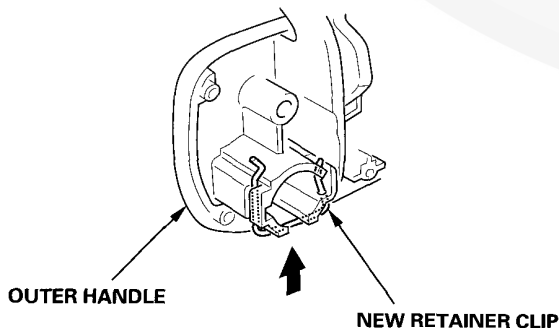

1. Remove the sunroof liner.
2. Remove the sunroof panel.
3. Remove the seal holder.
4. Installation is the reverse of the removal procedure.

► : Screw, nut locations

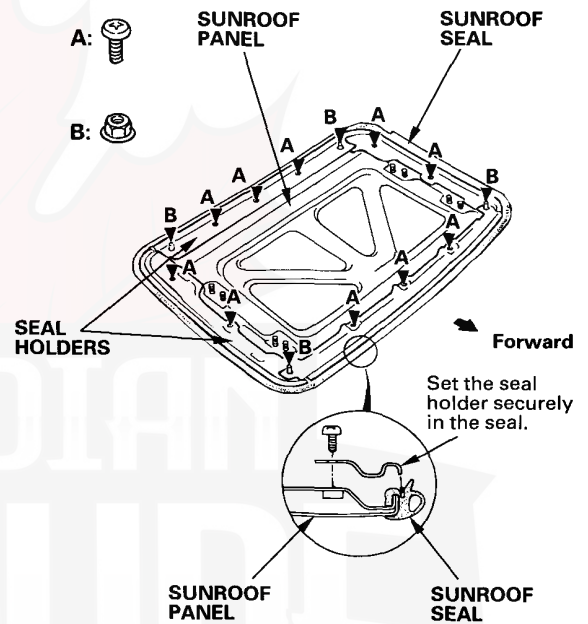

Seat Belt

Upper and Lower Anchor Bolt Construction

Front seat belt :

NOTE:

- Make sure you assemble the washers and collars on the upper and lower anchor bolts as shown.
- Remove the cap from the anchor.

Upper anchor bolt :

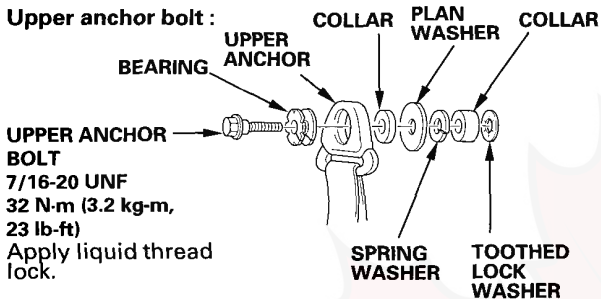

Lower anchor bolt (KY and KM models):

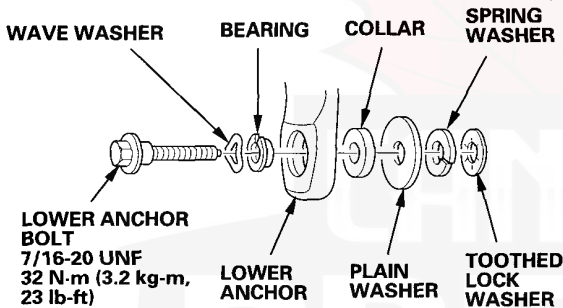

Lower anchor bolt (except KY and KM models):
TAKATA made :

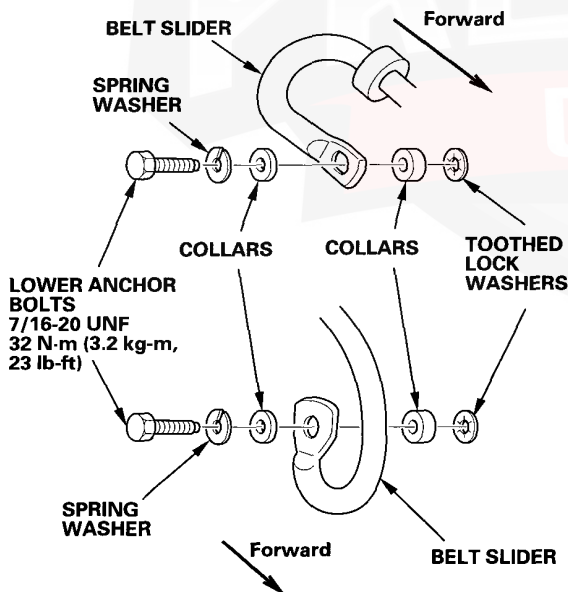

Dashboard

Component Removal/Installation

Knee bolster (KM model):

NOTE:

- Take care not to scratch the dashboard and related parts.

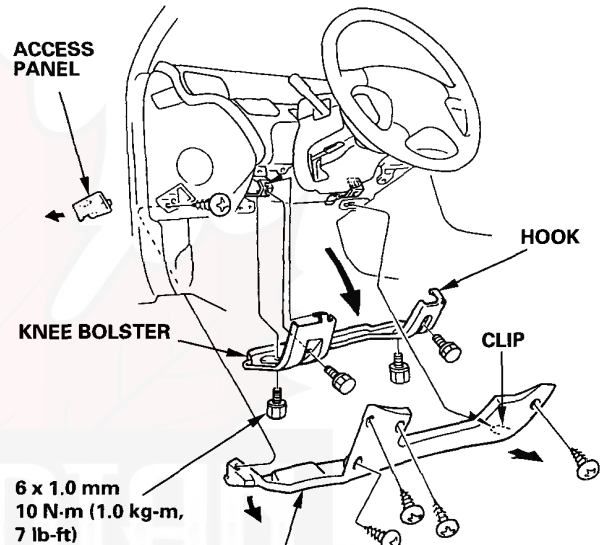

DASHBOARD LOWER COVER

Remove the screws and detach the clip, then remove the dashboard lower cover by pulling it rearward.



License Plate Trim / Side Sill Panel

License Plate Trim Replacement

For some models:

NOTE:

- Take care not to scratch the trunk lid.
- Remove the license plate.
- The numbers after the part name show the quantities of the parts used.

1. Open the trunk lid, then remove the mounting nuts.
2. Remove the upper clip.
3. Detach the center clips, then remove the license plate trim.
4. Installation is the reverse of the removal procedure.

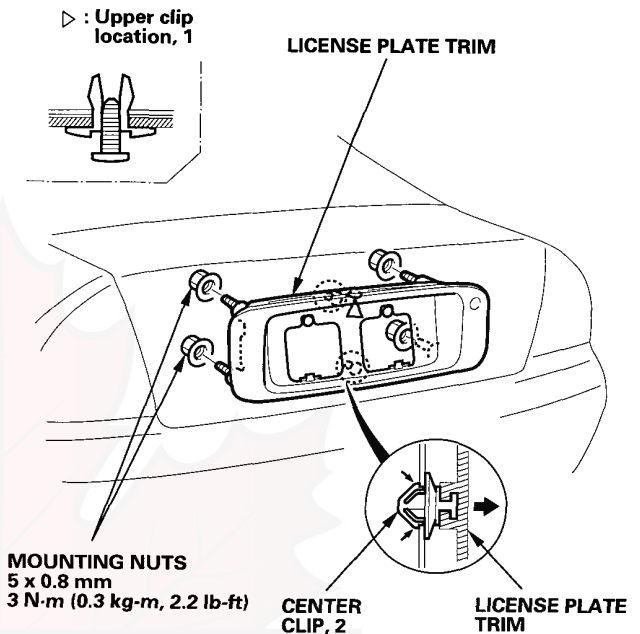

Side Sill Panel Replacement

► : Clip locations

A, 7

B, 7

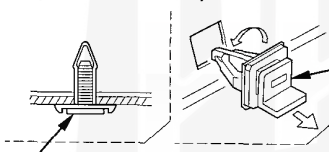

SIDE CLIP
Remove the side clips from the body by turning them 45°.

NOTE:

Loosen the screw, then remove the lower clip using a clip remover.

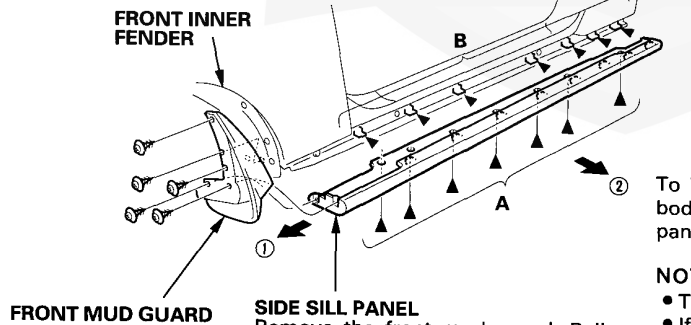

SIDE SILL PANEL
Remove the front mud guard. Pull away the front inner fender. Remove the lower clips, then remove the side sill panel by sliding it forward.

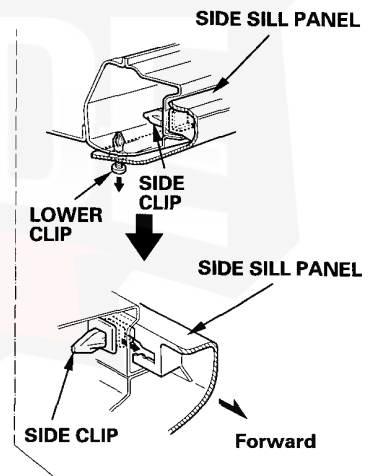

To install the side sill panel, remove the side clips from the body, install them on the side sill panel, then install the side sill panel on the car.

NOTE:

- Take care not to twist the side sill panel.
- If necessary, replace any damaged side and lower clips.

Air Conditioning

Circuit Diagram22-2

Compressor

Relief Valve Replacement22-3

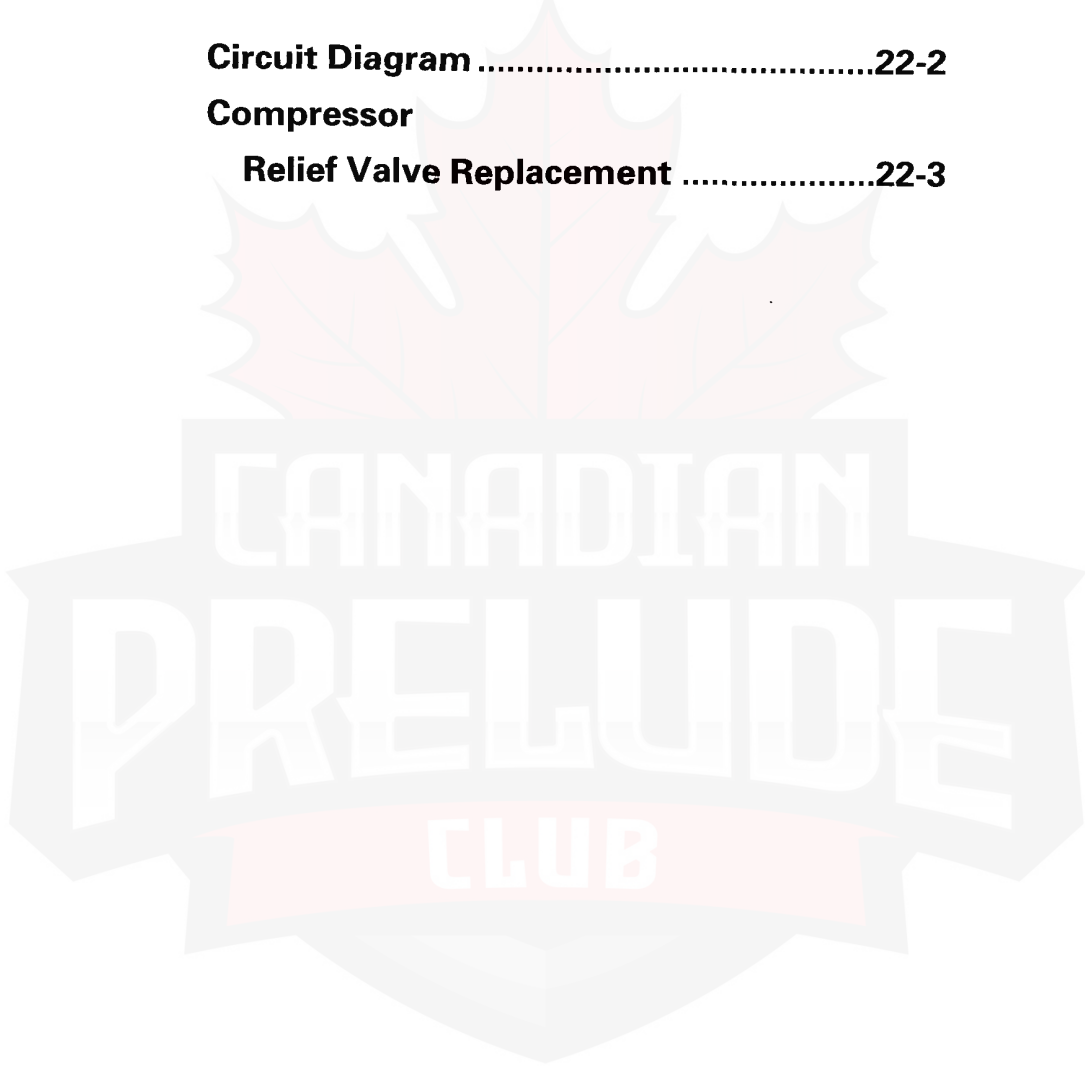

Outline of Model Changes

- The circuit diagram has been changed.
- The relief valve cover of Hadsys-made spiral-type compressor (HS-090L) has changed; related instructions were added.



Circuit Diagram

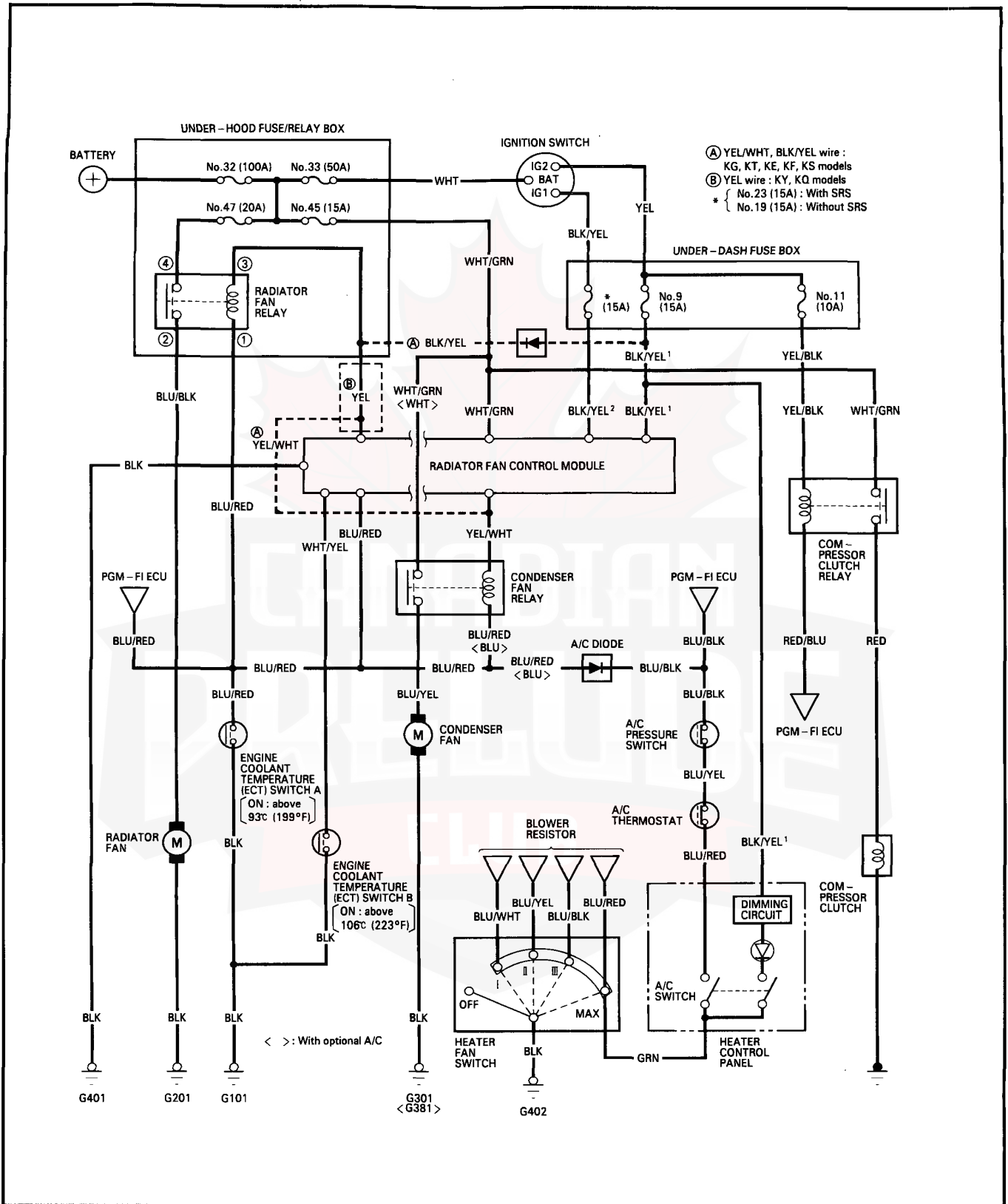



Compressor

Relief Valve Replacement

NOTE:

A relief valve, through which refrigerant has escaped once, must be replaced with a new one.

1. Discharge the refrigerant.
2. Remove the relief valve cover, relief valve and the O-ring.

NOTE:

- Do not let the compressor oil run out.
- Make sure there is no foreign matter in the system.

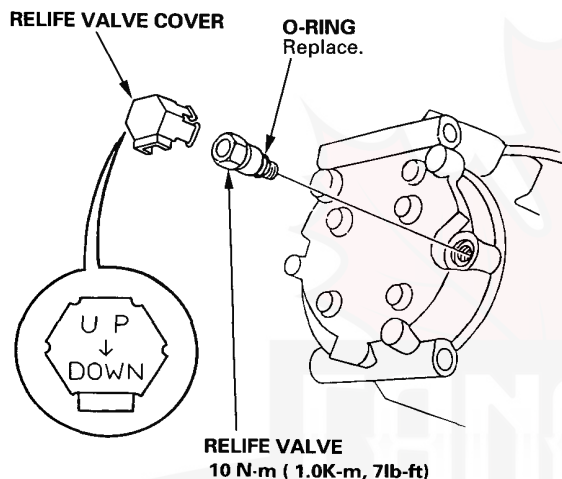

3. Clean the mating surfaces.
4. Replace the relief valve O-ring with a new one and apply a thin coat of refrigerant oil (SP- 10: P/N 38899 - P13 - 003) before installing it.

NOTE:

- To avoid contamination, do not return the oil to the container once dispensed, and never mix it with other refrigerant oils.
 - Immediately after using the oil, replace the cap on the container, and seal it to avoid moisture absorption.
 - Do not spill the refrigerant oil on the car; it may damage the paint; if the refrigerant oil contacts the paint, wash it off immediately.
5. Install and tighten the relief valve.
 6. Put the cover so on the relief valve that the arrow directs downwards as shown in the illustration above.
 7. Charge the system, and test its performance.

SUPPLEMENTAL RESTRAINT SYSTEM (SRS)

Some versions of the KE, KG, KF, KS Prelude models and the KM model include a driver's airbag, located in the steering wheel hub, and a front passenger's airbag, located in the dashboard above the glove box. The SRS unit of these model versions is not part of the airbag assembly and has built-in sensors (SRS Type III). Some other KE, KG, KF, KS model versions and the KQ model include only a driver's airbag, located in the steering wheel hub. The SRS unit of these model versions is part of the airbag assembly (SRS Type II). Information necessary to safely service the SRS is included in the Shop Manual Supplement 62SS020 (SRS Type II) and in the Shop Manual Supplement 62SS021 (SRS Type III). Items marked with an asterisk (*) on the contents page include, or are located near, SRS components.

Servicing, disassembling or replacing these items will require special precautions and tools, and should therefore be done by an authorized Honda dealer.

▲ WARNING

- **To avoid rendering the SRS inoperative, which could lead to personal injury or death in the event of a severe frontal collision, all SRS service work must be performed by an authorized Honda dealer.**
- **Improper service procedures, including incorrect removal and installation of the SRS, could lead to personal injury caused by unintentional activation of the airbag(s).**
- **Do not bump the SRS unit. Otherwise, the system may fail in case of a collision, or the airbags may deploy when the ignition switch is ON (II) (SRS Type III).**
- **All SRS electrical wiring harnesses are covered with yellow insulation. Related components are located in the steering column, front console, dashboard, dashboard lower panel, and, in case of some models, in the dashboard above the glove box. Do not use electrical test equipment on these circuits.**
- **Service work nearby and in the areas listed below may affect the SRS and must therefore be performed by an authorized Honda dealer.**

SRS Type II:

- Steering wheel (Be careful not to bump the steering wheel as the SRS unit (sensors), inflator, etc. are located in it.)
- Behind the dashboard
- Under-dash fuse/relay box

SRS Type III:

- Steering wheel
- Behind the dashboard
- Under-dash fuse/relay box
- Front console
- Car stereo unit and other accessories
- A/C heater

Electrical

Starting System

(M/T with Interlock Switch for KM model)

Component Location Index	23-2
Description	23-3
Circuit Diagram	23-4

* Interlock System (KM model)

Description	23-6
Circuit Diagram	23-7
Control Unit Input Test	23-8
Parking Pin Switch Test	23-9

* Shift Lever Position Indicator (KM model)

Component Location Index	23-10
Circuit Diagram	23-11
Indicator Input Test	23-12

* Integrated Control Unit (KM model)

Circuit Diagram	23-14
Input Test	23-16

Lights-on Reminder System (KM model)

Chime Test	23-21
------------------	-------

Stereo Sound System

Antenna Tube Replacement	23-22
Antenna Mast Installation	23-23

Power Mirrors

Actuator Replacement	23-24
----------------------------	-------

Power Windows

(With Key-off Timer for KM model)

Component Location Index	23-26
Circuit Diagram	23-27

Sunroof

(With Key-off Timer for KM model)

Circuit Diagram	23-28
-----------------------	-------

*Read the SRS precautions in the Shop Manuals 62SS020 and 62SS021, then install the short connector(s) on the airbag(s) before working in these areas.

Outline of Model Changes

- The cooling fan fuse capacity has been changed from 15 A to 20 A.
- Starting System: A clutch interlock switch has been added for the KM model.
- Interlock System: A parking pin switch has been added for the KM model.
- Shift Lever Position Indicator: The circuit diagram has been changed for the KM model.
- Integrated Control Unit: The circuit diagram has been changed for the KM model.
- Stereo Sound System: It is now possible to replace the antenna tube.
- Power Mirrors: It is now possible to replace the power mirror actuator.
- Power Windows: A key-off timer has been added for the KM model.
- Sunroof: A key-off timer has been added for the KM model.



Starting System (M/T with Interlock Switch for KM model)

Component Location Index

BATTERY

CLUTCH INTERLOCK SWITCH
Test, page 23-5

STARTER

STARTER CUT RELAY
Wire colors: BLK/WHT,
BLK/WHT, BLK/GRN,
and BLK/RED

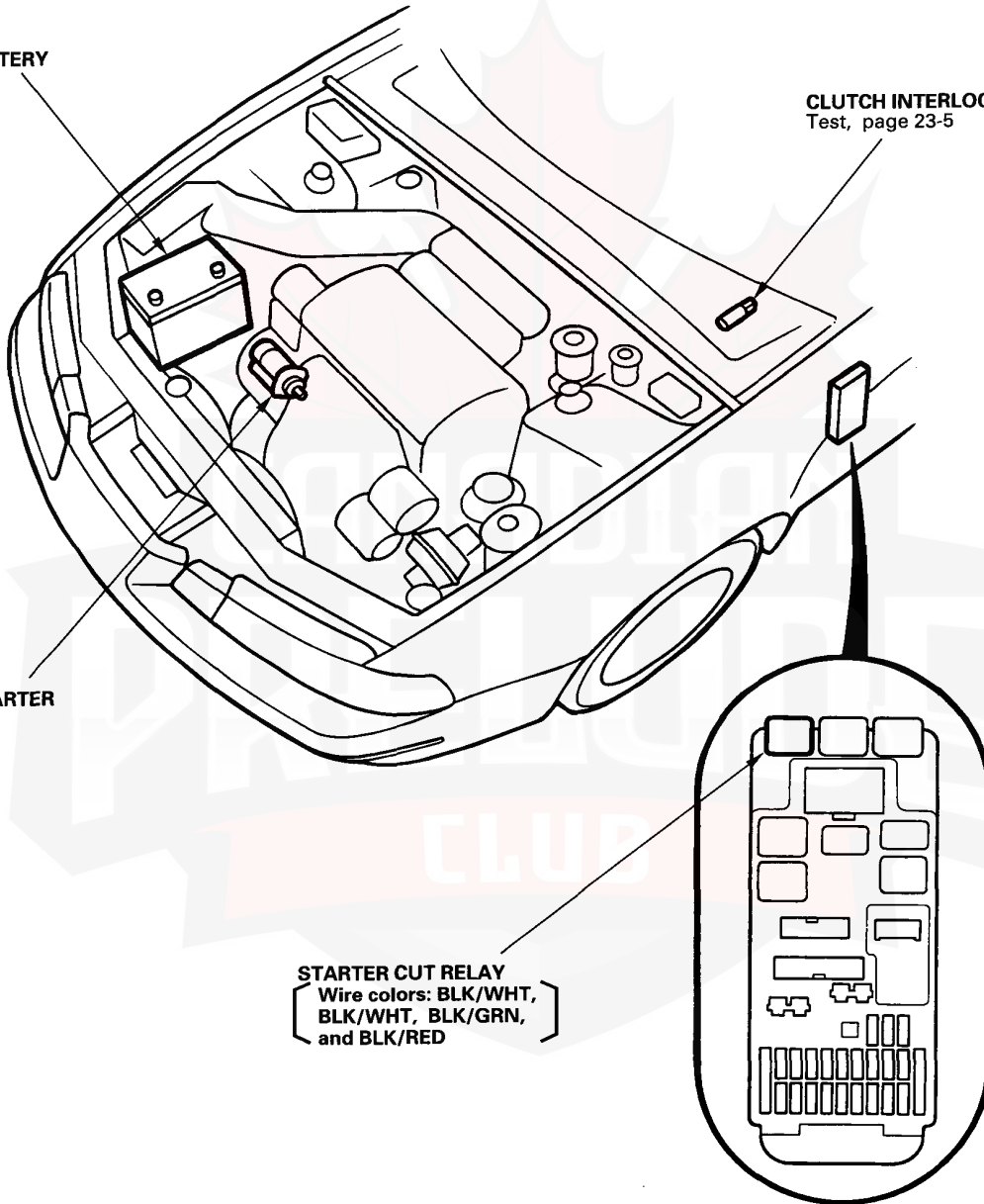



Description

Starter Interlock System (M/T):

The starter interlock system prevents the engine from starting unless the clutch pedal is fully depressed.

The clutch interlock switch turns on at the position where the clutch disengages: 15–20 mm (0.6–0.8 in) from the fully depressed position.

NOTE:

A full stroke of the clutch pedal is 135–145 mm (5.3–5.7 in) from the fully released position.

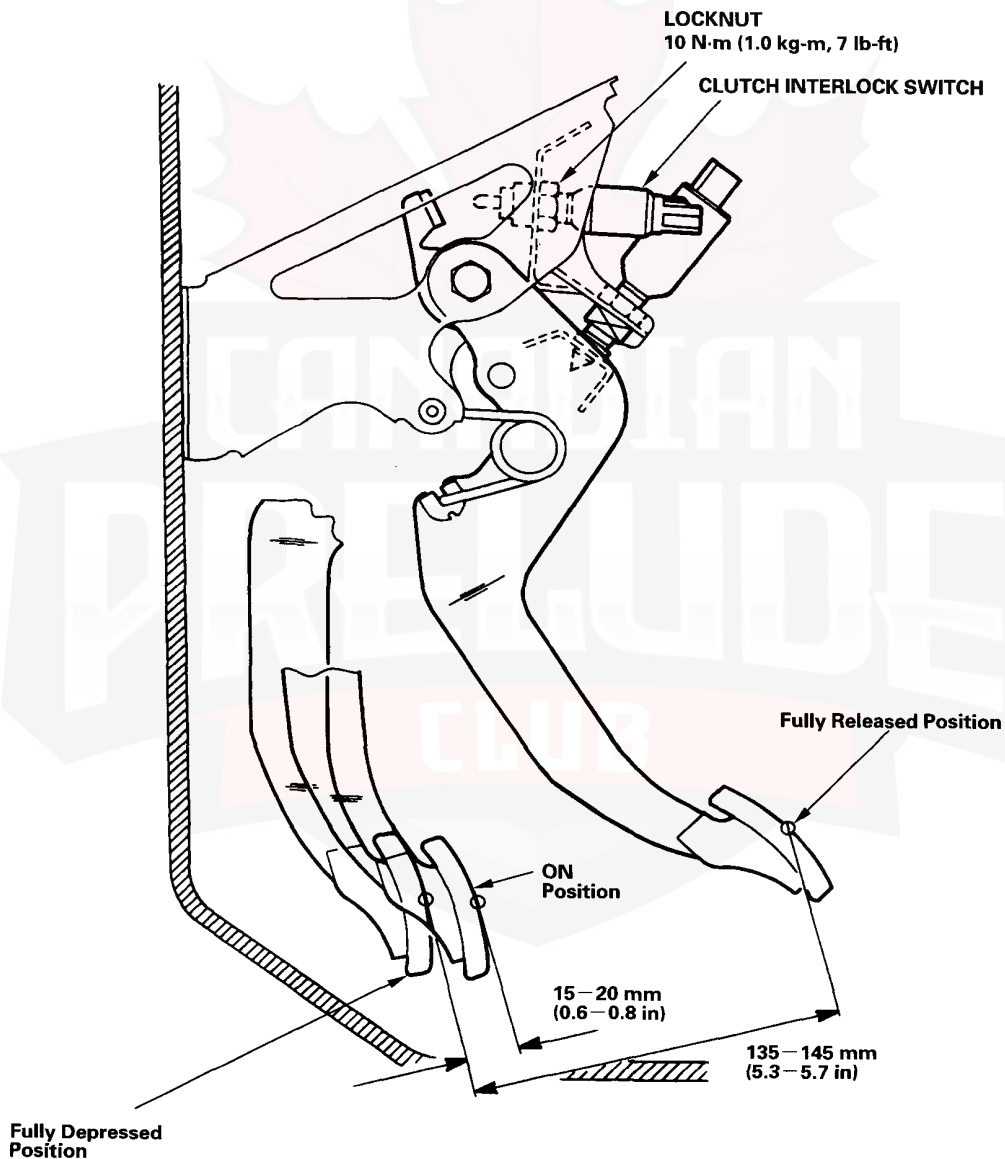

Starting System (M/T with Interlock Switch for KM model)

Circuit Diagram

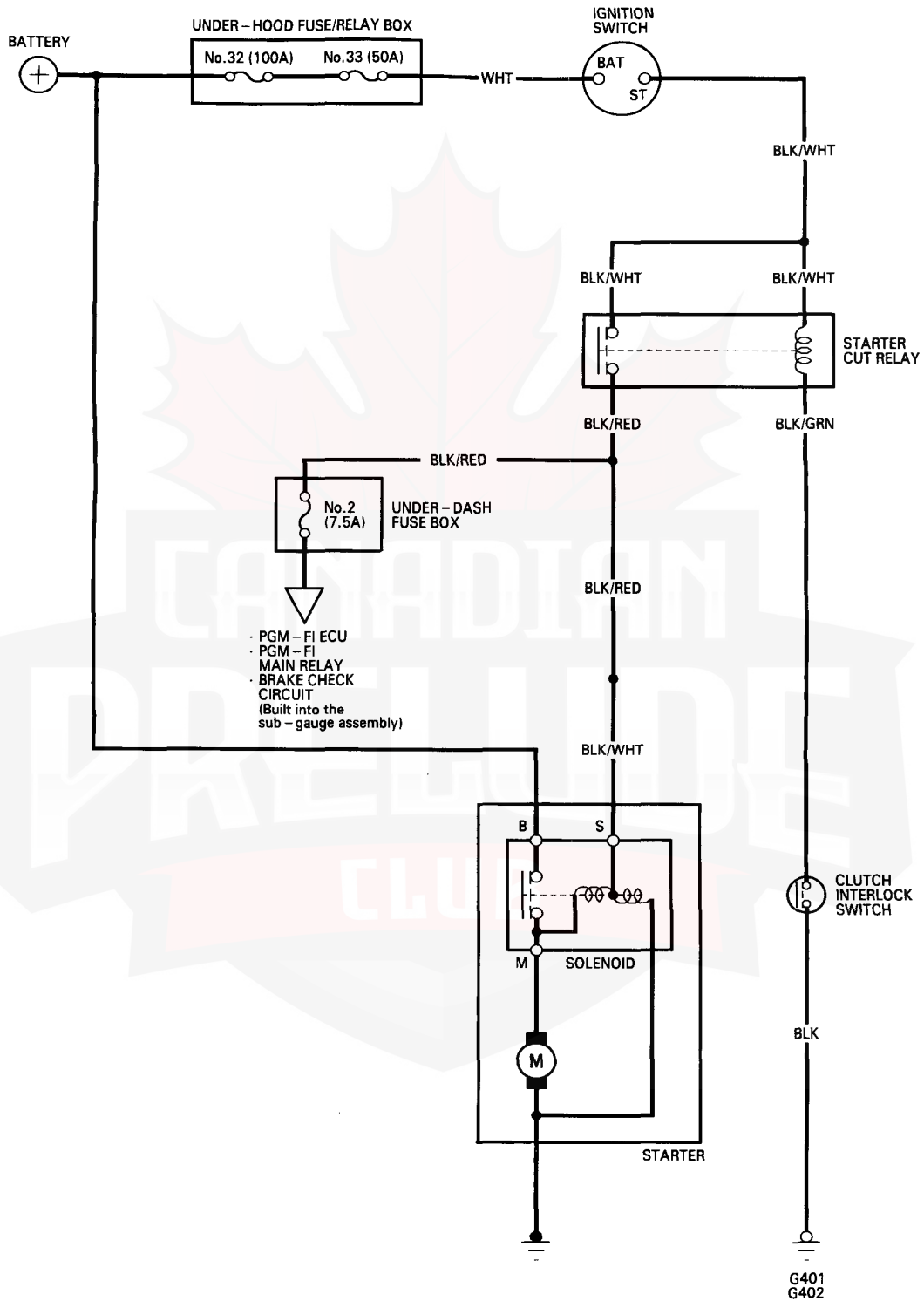



Clutch Interlock Switch Test

1. Remove the dashboard lower cover and knee bolster, then disconnect the 2-P connector from the switch.
2. Check for continuity between the terminals according to the table.

Terminal	1	2
Clutch Pedal		
RELEASED		
PUSHED		

CLUTCH
INTERLOCK
SWITCH

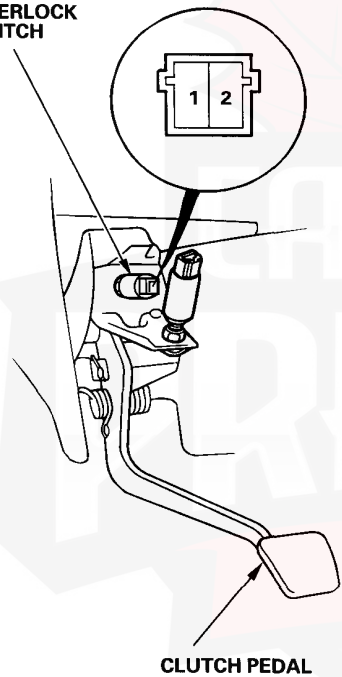

3. If necessary, replace the switch or adjust the switch position (see page 23-3).

Interlock System (KM model)

Description

The car is equipped with the following devices to prevent inadvertent shifting:

- Key cylinder with interlocked ignition key (Key Interlock System)
- Shift lever with shift lock (Shift Lock System)

Key Interlock System:

When the shift lever is in any other position than **P** or is not securely locked in **P** (parking pin switch is ON), a solenoid is activated, making it impossible to remove the ignition key from the ignition switch. To be able to remove the key, the shift lever must be in **P** and must be securely locked in this position (parking pin switch must be turned off by the lock pin)

The shift lever is in any other position than **P**, and the parking pin switch is ON:

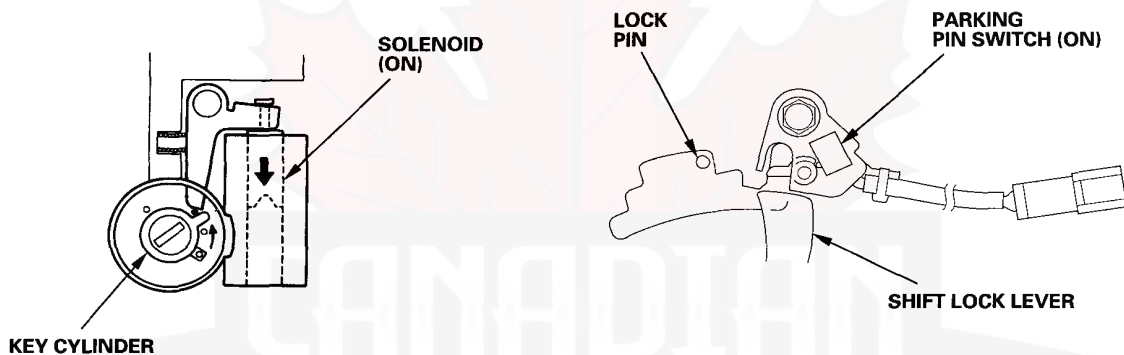

The shift lever is in **P**, and the parking pin switch is OFF:

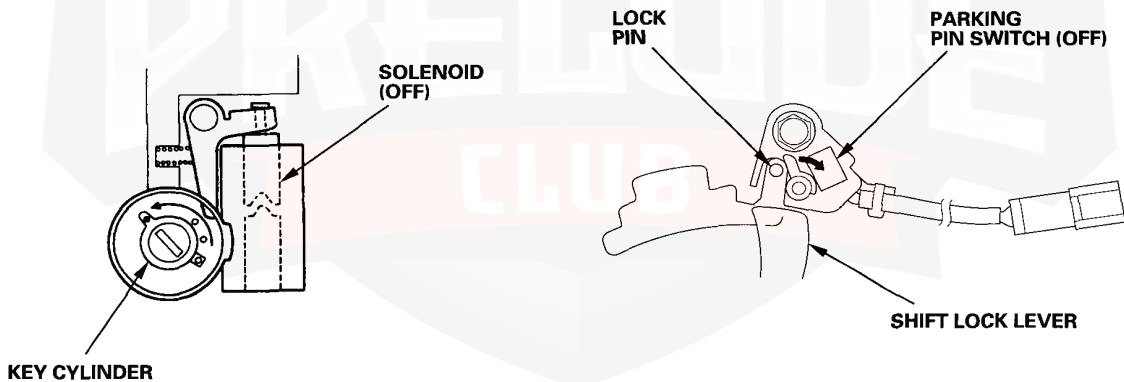

Shift Lock System:

The shift lock system prevents the shift lever from moving to another position than **P** unless you step on the brake pedal.

NOTE:

- The shift lever cannot be shifted when the brake pedal and the accelerator are depressed at the same time.
- In case of system malfunction, the shift lever can be released by pushing a key into the release slot near the shift lever.



Circuit Diagram

NOTE:

Several different wires have the same color. They have been given a number suffix to distinguish them (for example, GRN/WHT¹ and GRN/WHT² are not the same).

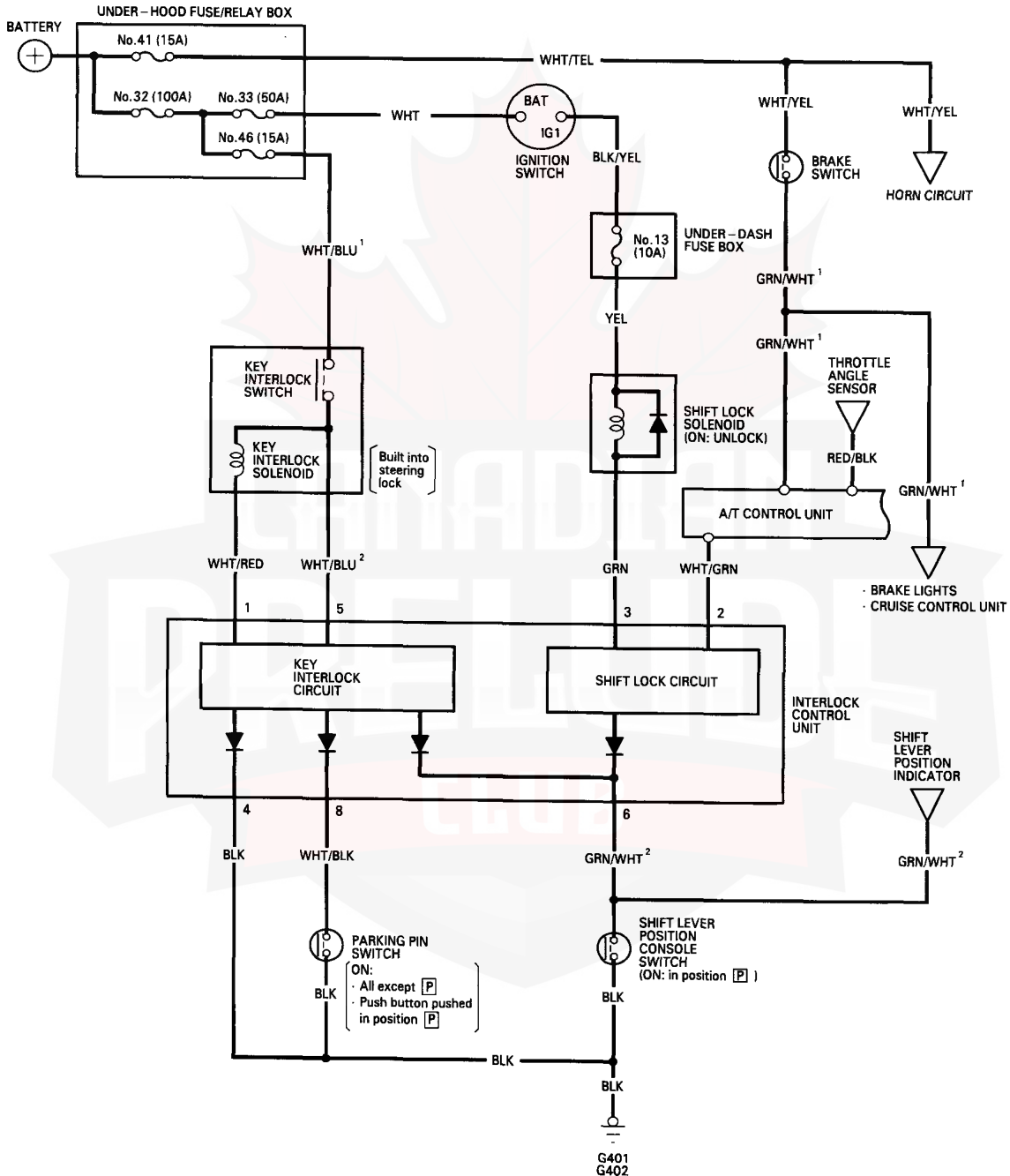

Interlock System (KM model)

Control Unit Input Test

1. Disconnect the 8-P connector from the interlock control unit.
2. Inspect the connector and socket terminals to be sure they are all making good contact.
 - If the terminals are bent, loose or corroded, repair them as necessary, and recheck the system.
 - If the terminals look OK, make the following input tests at the connector.
 - If a test indicates a problem, find and correct the cause, then recheck the system.
 - If all the input tests prove OK, substitute a known-good control unit, and recheck the system. If the check is OK, the control unit must be faulty; replace it.

NOTE:

If the shift lock solenoid clicks when the ignition switch is turned ON (II) and you step on the brake pedal (with the shift lever in **P**), the shift lock system is electronically normal; if the shift lever cannot be shifted from **P**, test the shift lever position switch.

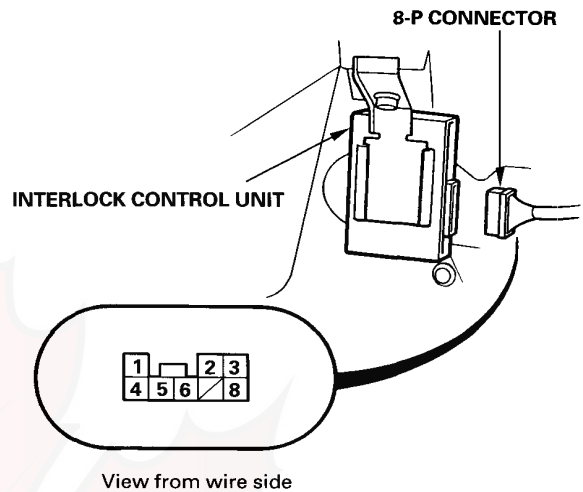

Shift Lock System:

Terminal No.	Wire	Test condition	Test: Desired result	Possible cause if result is not obtained
2	WHT/GRN	Ignition switch ON (II), brake pedal pushed	Check for voltage to ground: There should be battery voltage.	<ul style="list-style-type: none"> • Blown No.41 (15 A) fuse in the under-hood fuse/relay box • Faulty A/T control unit • Faulty brake switch • Faulty throttle angle sensor • An open in the wire
		Ignition switch ON, brake pedal and accelerator pushed at the same time	Check for voltage to ground: There should be less than battery voltage.	
6	GRN/WHT ²	Shift lever in P	Check for continuity to ground: There should be continuity.	<ul style="list-style-type: none"> • Faulty shift lever position switch • Poor ground (G401, G402) • An open in the wire
3	GRN	Ignition switch ON (II)	Check for voltage to ground: There should be battery voltage.	<ul style="list-style-type: none"> • Blown No.13 (10 A) fuse • Faulty shift lock solenoid • An open in the wire

Key Interlock System:

Terminal No.	Wire	Test condition	Test: Desired result	Possible cause if result is not obtained
4	BLK	Under all conditions	Check for continuity to ground: There should be continuity.	<ul style="list-style-type: none"> • Poor ground (G401, G402) • An open in the wire
6	GRN/WHT ²	Shift lever in P	Check for continuity to ground: There should be continuity.	<ul style="list-style-type: none"> • Faulty shift lever position switch • Poor ground (G401, G402) • An open in the wire
1	WHT/RED	Ignition switch turned to ACC (I), the key pushed all the way in	Check for voltage to ground: There should be battery voltage.	<ul style="list-style-type: none"> • Blown No.46 (15 A) fuse in the under-hood fuse/relay box • Faulty steering lock assembly (key interlock solenoid) • An open in the wire
5	WHT/BLU ²			
8	WHT/BLK	Shift lever in P , and push button pressed	Check for continuity to ground: There should be continuity.	<ul style="list-style-type: none"> • Faulty parking pin switch • Poor ground (or short to ground) • An open in the wire
		Shift lever in P , and push button released	Check for continuity to ground: There should be no continuity.	



Parking Pin Switch Test

1. Remove the console, then disconnect the 2-P connector from the switch.
2. Check for continuity between the terminals in each button position according to the table.

Terminal		1	2
Position			
Shift lever in position P	Push button pushed		
	Push button released		

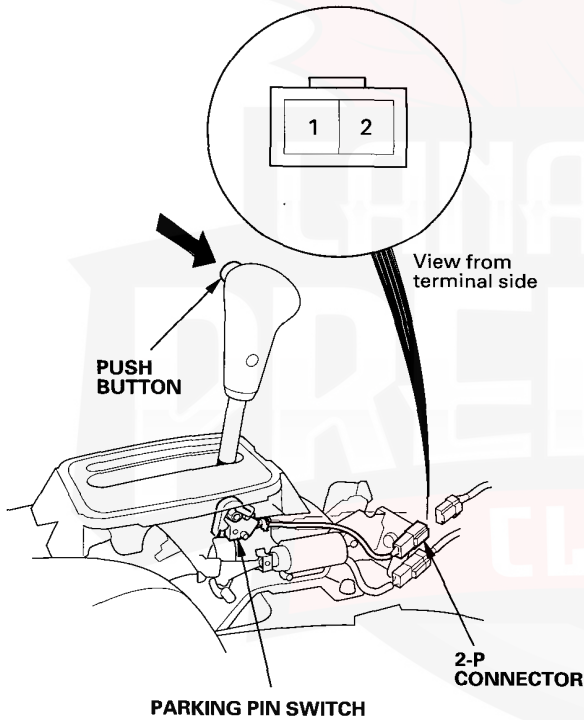

3. If necessary, replace the self-locking nut and the parking pin switch.

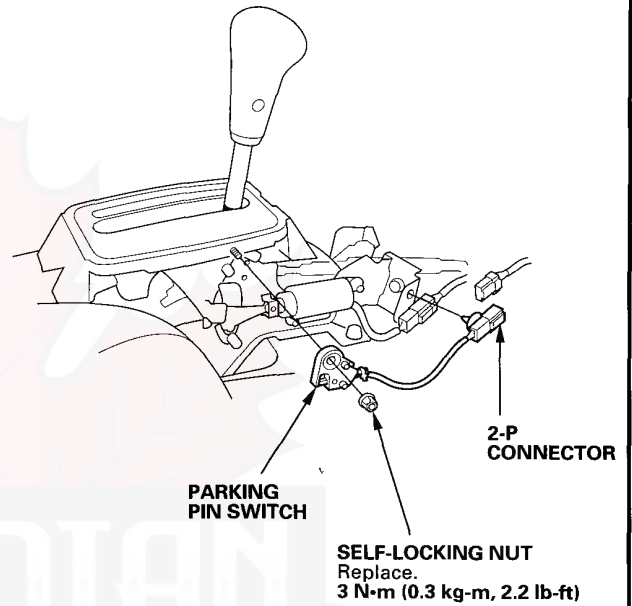

Shift Lever Position Indicator (KM model)

Component Location Index

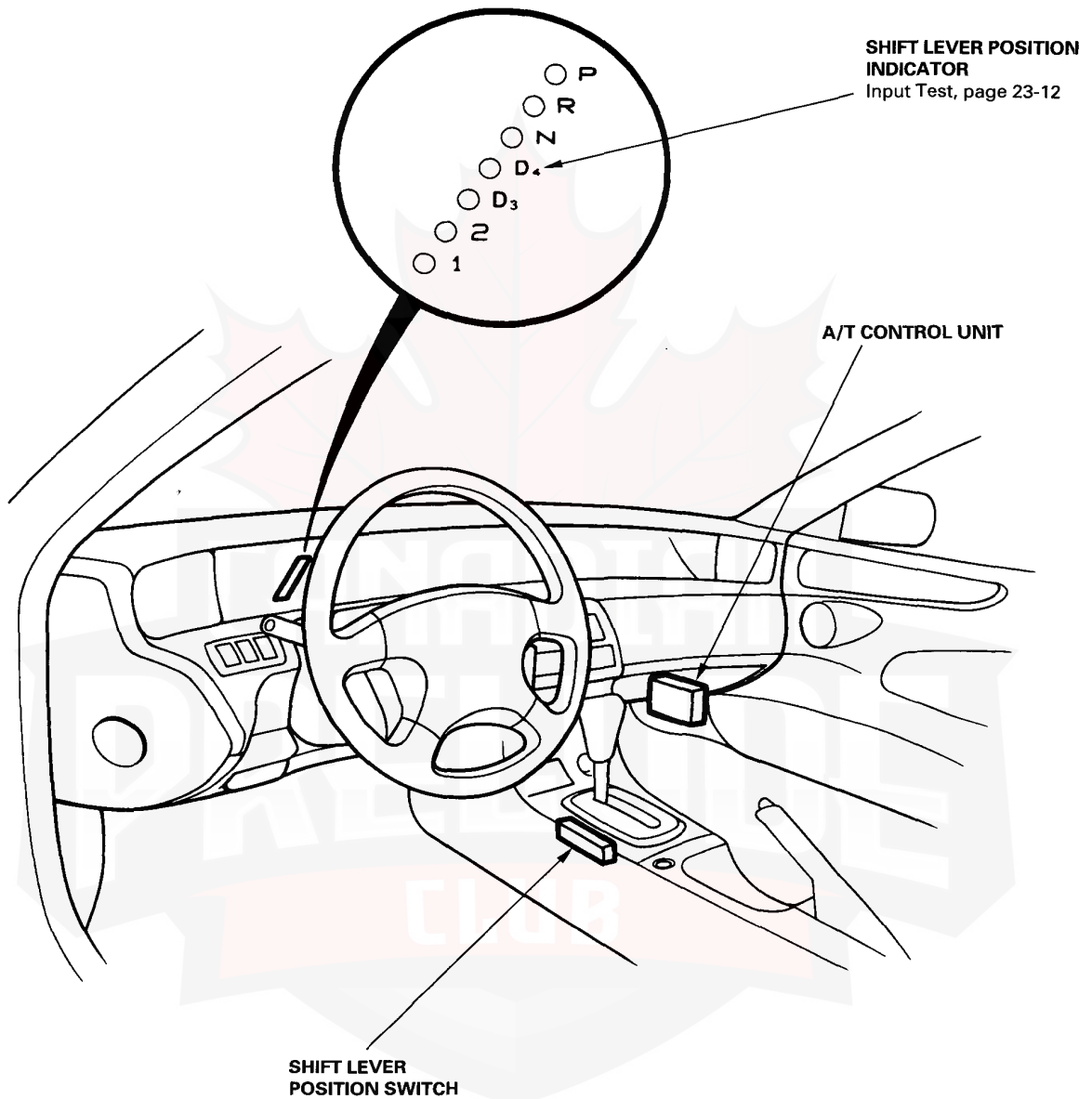



Circuit Diagram

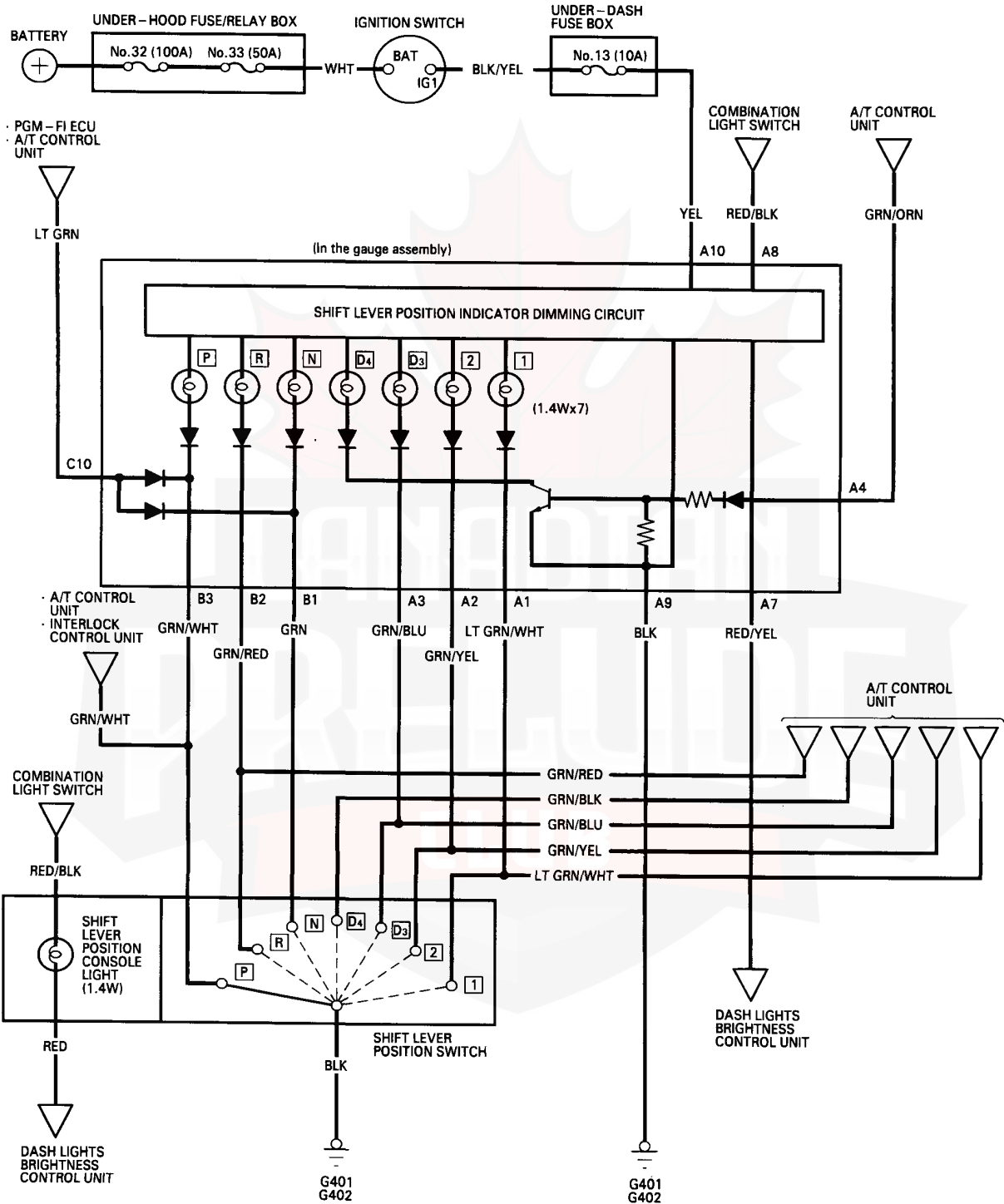

Shift Lever Position Indicator (KM model)

Indicator Input Test

1. Remove the main gauge assembly from the dashboard.
2. Disconnect the 5-P and two 10-P connectors from the main gauge assembly.
3. Inspect the connector and socket terminals to be sure they are all making good contact.
 - If the terminals are bent, loose or corroded, repair them as necessary, and recheck the system.
 - If the terminals look OK, make the following input tests at the connectors.
 - If a test indicates a problem, find and correct the cause, then recheck the system.
 - If all the input tests prove OK, the indicator must be faulty; replace the gauge assembly.

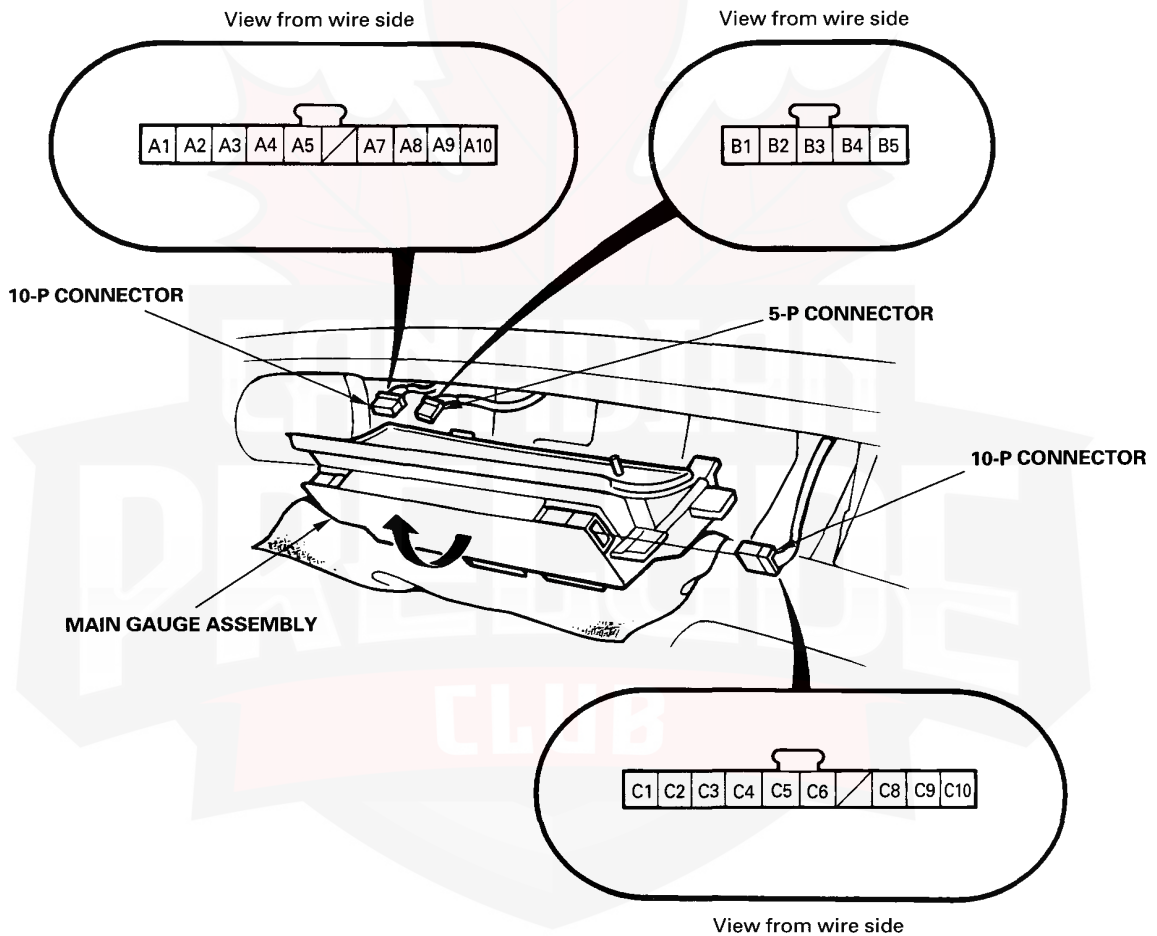



Terminal No.	Wire	Test condition	Test: Desired result	Possible cause if result is not obtained
A9	BLK	Under all conditions	Check for continuity to ground: There should be continuity.	<ul style="list-style-type: none"> • Poor ground (G401, G402) • An open in the wire
A10	YEL	Ignition switch ON	Check for voltage to ground: There should be battery voltage.	<ul style="list-style-type: none"> • Blown No.13 (10 A) fuse (In the under-dash fuse box) • An open in the wire
B3	GRN/WHT	Shift lever in P NOTE: Don't push the brake pedal.	Check for continuity to ground: There should be continuity. NOTE: There should be no continuity in any other position.	<ul style="list-style-type: none"> • Faulty shift lever position switch • Poor ground (G401, G402) • An open in the wire
B2	GRN/RED	Shift lever in R		
B1	GRN	Shift lever in N		
A3	GRN/BLU	Shift lever in D_s		
A2	GRN/YEL	Shift lever in 2		
A1	LT GRN/ WHT	Shift lever in 1		
A7 A8	RED/YEL and RED/BLK	Combination light switch ON, and dash lights brightness control dial on full bright	Check for voltage between terminals A7 and A8: There should be battery voltage.	<ul style="list-style-type: none"> • Faulty dash lights brightness control system • An open in the wire
A4	GRN/ORN	Ignition switch ON, and shift lever in any position except D_s	Check for voltage to ground: There should be battery voltage for two seconds after the ignition switch is turned ON, and less than 1 V two seconds later.	<ul style="list-style-type: none"> • Faulty A/T control unit • An open in the wire
C10	LT GRN	Ignition switch ON	Check for voltage to ground: There should be more than 5 V.	<ul style="list-style-type: none"> • Faulty PGM-FI ECU or A/T control unit • An open in the wire

Integrated Control Unit (KM model)

Circuit Diagram

Description

An integrated control unit, located in the left kick panel, integrates the functions of the key-in/seat belt reminder, side marker light flasher, wiper/washer, lights-on reminder, rear window defogger timer, entry light timer, key-off timer, and engine oil pressure indicator flasher circuits.

NOTE:

Different wires with the same color have been given a number suffix to distinguish them (for example, GRN/RED¹ and GEN/RED² are not the same).

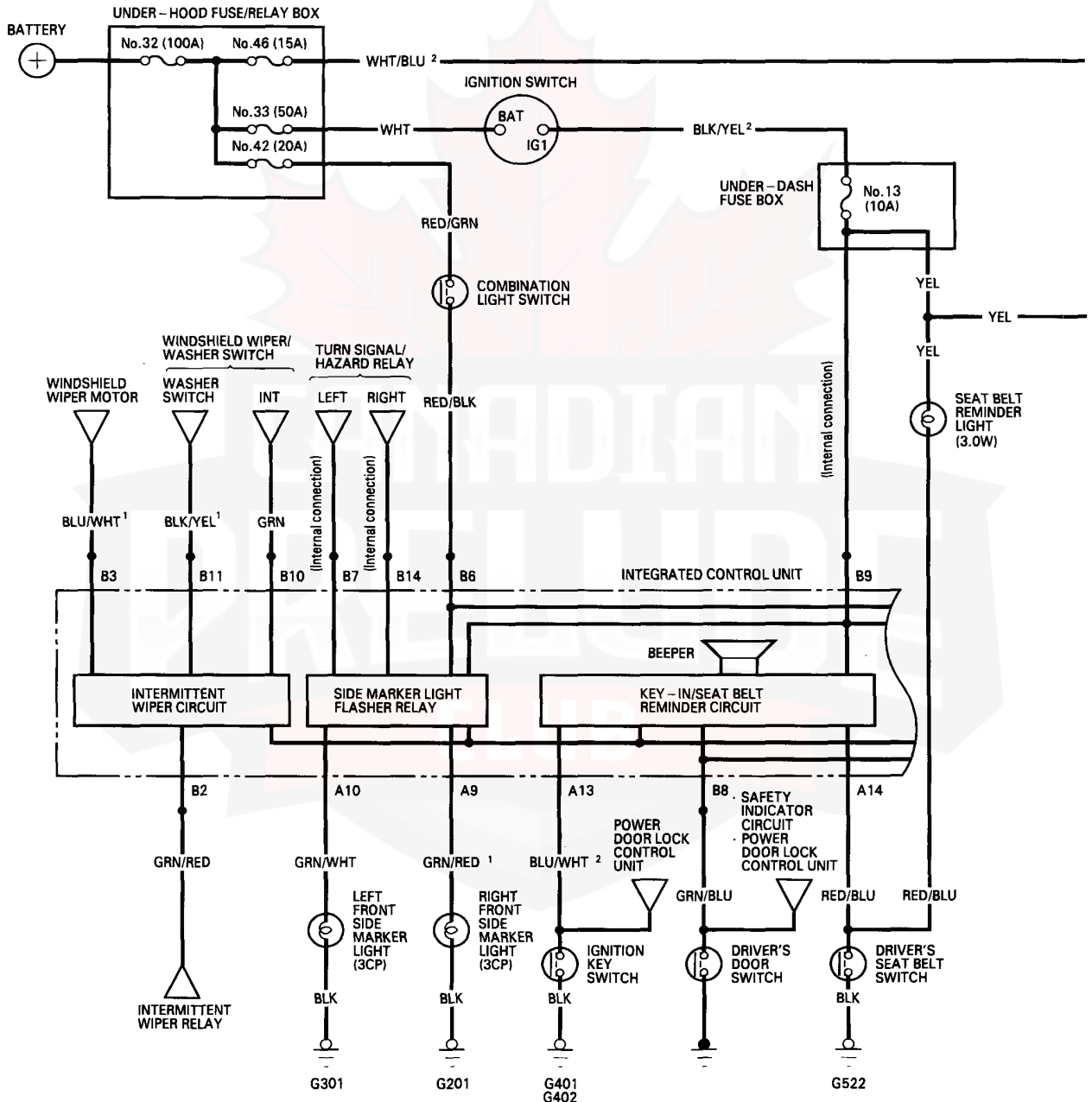

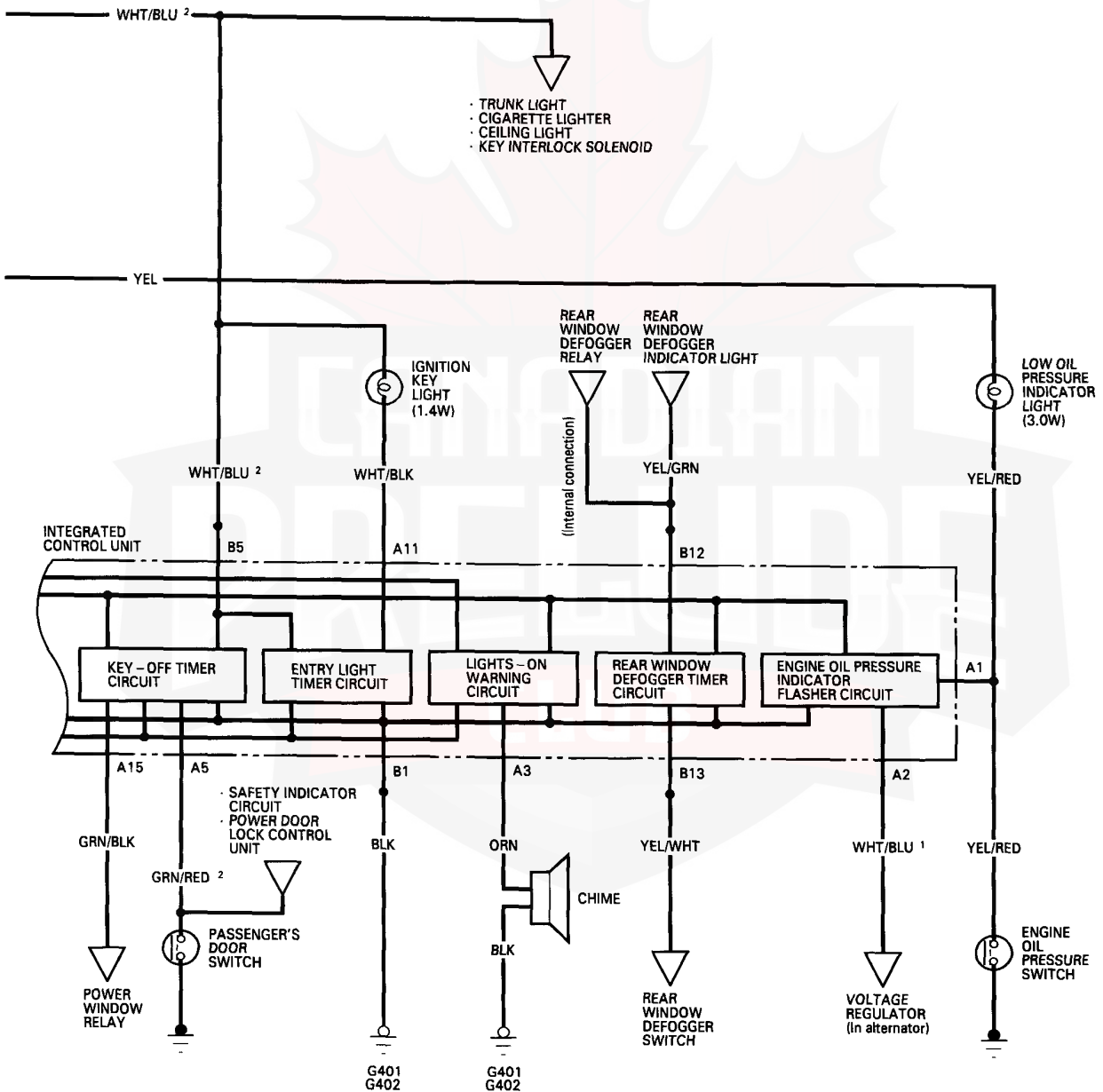

Integrated Control Unit (KM model)

Input Test

1. Remove the left kick panel, then disconnect the 16-P connector from the integrated control unit.
2. Remove the under-dash fuse box, then remove the integrated control unit.
3. Inspect the connector and the socket terminals to be sure they are all making good contact.
 - If the terminals are bent, loose, or corroded, repair them as necessary, and recheck the system.
 - If the terminals look OK, make the following input tests at the connector and the socket.
 - If a test indicates a problem, find and correct the cause, then recheck the system.
 - If all the input tests prove OK, the control unit must be faulty; replace it.

NOTE:

- Different wires with the same color have been given a number suffix to distinguish them (for example, GRN/RED¹ and GRN/RED² are not the same).
- Do not disconnect any connectors from the under-dash fuse/box except the one for the integrated control unit.

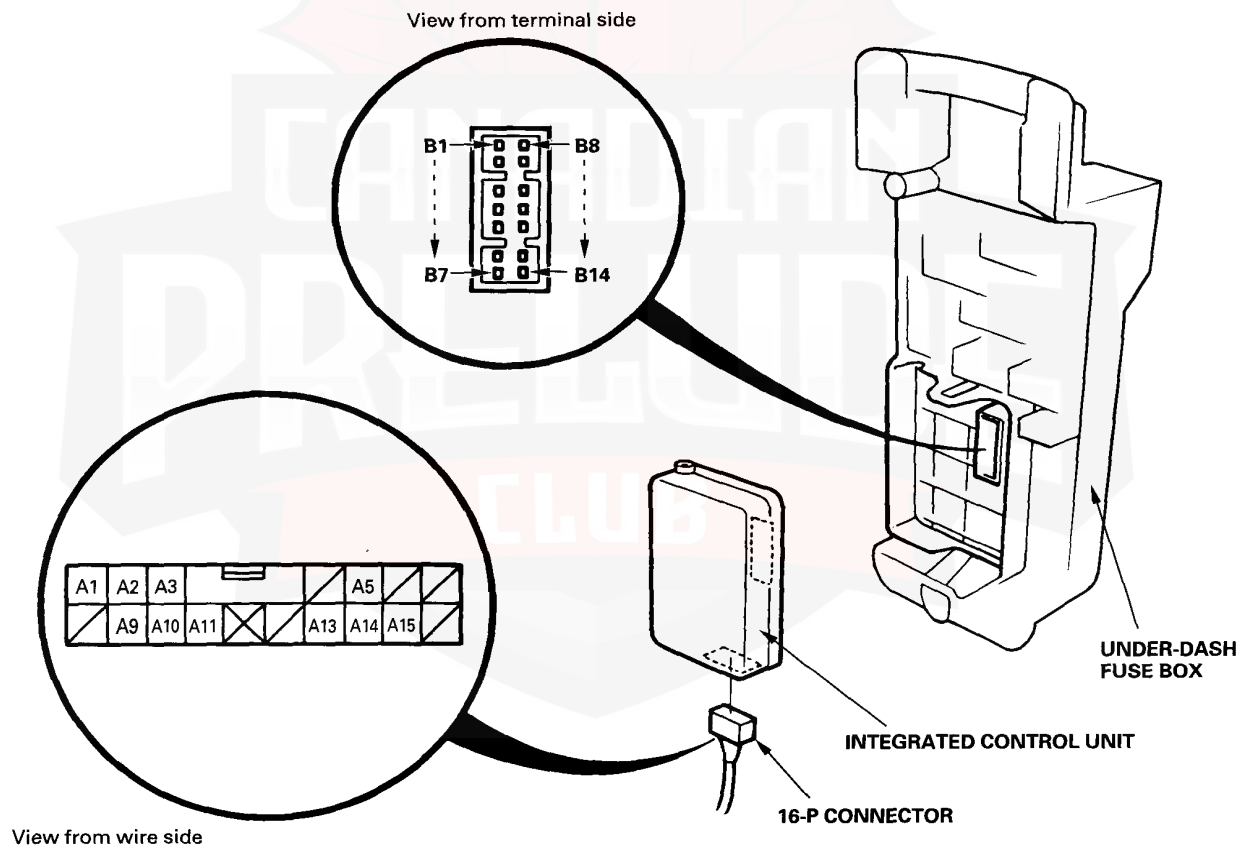

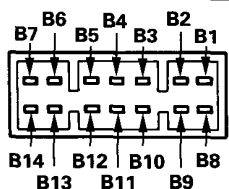

View from terminal side of the under-dash fuse box socket

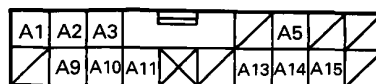

View from wire side of the harness connector

Wiper System:

Terminal

Terminal No.	Wire	Test condition	Test: Desired result	Possible cause if result is not obtained
B1	—	Under all conditions	Check for continuity to ground: There should be continuity.	<ul style="list-style-type: none"> • Poor ground (G401, G402) • An open in the wire
B2	—	Ignition switch ON	Check for voltage to ground: There should be battery voltage.	<ul style="list-style-type: none"> • Blown No.17 (30 A) fuse (In the under-dash fuse box) • Faulty intermittent wiper relay • An open in the wire
B10	—	Ignition switch ON, and wiper switch at INT position	Check for voltage to ground: There should be battery voltage.	<ul style="list-style-type: none"> • Blown No.17 (30 A) fuse (In the under-dash fuse box) • Faulty wiper switch • An open in the wire
B11	—	Ignition switch ON, and washer switch ON	Check for voltage to ground: There should be battery voltage.	<ul style="list-style-type: none"> • Blown No.17 (30 A) fuse (In the under-dash fuse box) • Faulty wiper switch • An open in the wire
B3	—	Ignition switch ON	Check for voltage to ground: There should be battery voltage.	<ul style="list-style-type: none"> • Blown No.17 (30 A) fuse (In the under-dash fuse box) • Faulty wiper switch • Faulty windshield wiper motor • An open in the wire

Side Marker Flasher Light System:

Terminal

Terminal No.	Wire	Test condition	Test: Desired result	Possible cause if result is not obtained
B1	—	Under all conditions	Check for continuity to ground: There should be continuity.	<ul style="list-style-type: none"> • Poor ground (G401, G402) • An open in the wire
B9	—	Ignition switch ON	Check for voltage to ground: There should be battery voltage.	<ul style="list-style-type: none"> • Blown No.13 (10 A) fuse (In the under-dash fuse box) • An open in the wire
B6	—	Headlight switch ON	Check for voltage to ground: There should be battery voltage.	<ul style="list-style-type: none"> • Blown No.42 (20 A) fuse (In the under-hood fuse/relay box) • Faulty combination light switch • An open in the wire
B7	—	Ignition switch ON, and turn signal switch to "Left"	Check for voltage to ground: It should change from 0–12–0 V repeatedly.	<ul style="list-style-type: none"> • Blown No.13 (10 A) fuse (In the under-dash fuse box) • Faulty turn signal/hazard relay • An open in the wire
B14	—	Ignition switch ON, and turn signal switch to "Right"		
A10	GRN/WHT	Connect the B5 terminal to the A10 (or A9) terminal.	Check front side marker light operation: Left (or Right) front side marker light should come on as the battery is connected.	<ul style="list-style-type: none"> • Blown bulb • Poor ground [G301 (or G201)] • An open in the wire
A9	GRN/RED ¹			

(cont'd)

Integrated Control Unit (KM model)

Input Test (cont'd)

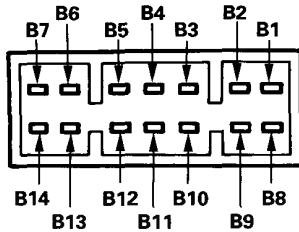

View from terminal side of the under-dash fuse box socket

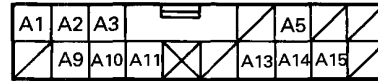

View from wire side of the harness connector

Key-in/Seat Belt Reminder System:

Terminal No.	Wire	Test condition	Test: Desired result	Possible cause if result is not obtained
B1	—	Under all conditions	Check for continuity to ground: There should be continuity.	<ul style="list-style-type: none"> • Poor ground (G401, G402) • An open in the wire
B8	—	Driver's door open	Check for continuity to ground: There should be continuity. NOTE: Before testing, remove the No.46 (15 A) fuse from the under-hood fuse/relay box.	<ul style="list-style-type: none"> • Faulty driver's door switch • An open in the wire
A13	BLU/WHT ²	Ignition key is inserted into the ignition switch.	Check for voltage to ground: There should be 1 V or less.	<ul style="list-style-type: none"> • Faulty ignition key switch • Poor ground (G401, G402) • An open in the wire
A14	RED/BLU	Ignition switch ON, and driver's seat belt unbuckled	Check for voltage to ground: There should be 1 V or less.	<ul style="list-style-type: none"> • Faulty seat belt switch • Poor ground (G522) • An open in the wire
B9	—	Ignition switch ON	Check for voltage to ground: There should be battery voltage.	<ul style="list-style-type: none"> • Blown No.13 (10 A) fuse (In the under-dash fuse box)

Key-off Timer System:

Terminal No.	Wire	Test condition	Test: Desired result	Possible cause if result is not obtained
B1	—	Under all conditions	Check for continuity to ground: There should be continuity.	<ul style="list-style-type: none"> • Poor ground (G401, G402) • An open in the wire
B5	—	Under all conditions	Check for voltage to ground: There should be battery voltage.	<ul style="list-style-type: none"> • Blown No.46 (15 A) fuse (In the under-hood fuse/relay box) • An open in the wire
B8	—	Driver's door open	Check for continuity to ground: There should be continuity. NOTE: Before testing, remove the No.46 (15 A) fuse from the under-hood fuse/relay box.	<ul style="list-style-type: none"> • Faulty driver's door switch • An open in the wire
A5	GRN/RED ²	Passenger's door open	Check for continuity to ground: There should be continuity. NOTE: Before testing, remove the No.46 (15 A) fuse from the under-hood fuse/relay box.	<ul style="list-style-type: none"> • Faulty door switch • An open in the wire
A15	GRN/BLK	Connect the B5 terminal to the A15 terminal.	Check window operation: The power windows should work with the key OFF.	<ul style="list-style-type: none"> • Faulty power window relay • Poor ground (G401, G402) • An open in the wire

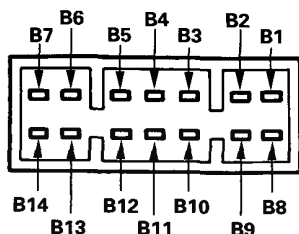

View from terminal side of the under-dash fuse box socket

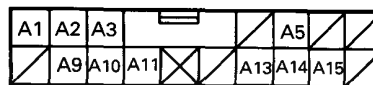

View from wire side of the harness connector

Entry Light Timer System:

Terminal No.	Wire	Test condition	Test: Desired result	Possible cause if result is not obtained
B1	—	Under all conditions	Check for continuity to ground: There should be continuity.	<ul style="list-style-type: none"> • Poor ground (G401, G402) • An open in the wire
B5	—	Under all conditions	Check for voltage to ground: There should be battery voltage.	<ul style="list-style-type: none"> • Blown No.46 (15 A) fuse (In the under-hood fuse/relay box) • An open in the wire
A11	WHT/BLK	Under all conditions	Attach to ground: Ignition key light should come on.	<ul style="list-style-type: none"> • Blown bulb • An open in the wire
B8	—	Driver's door open	Check for continuity to ground: There should be continuity. NOTE: Before testing, remove the No.46 (15 A) fuse from the under-hood fuse/relay box.	<ul style="list-style-type: none"> • Faulty driver's door switch • An open in the wire

Lights-on Reminder System:

Terminal No.	Wire	Test condition	Test: Desired result	Possible cause if result is not obtained
B1	—	Under all conditions	Check for continuity to ground: There should be continuity.	<ul style="list-style-type: none"> • Poor ground (G401, G402) • An open in the wire
B6	—	Headlight switch ON	Check for voltage to ground: There should be battery voltage.	<ul style="list-style-type: none"> • Blown No.42 (20 A) fuse (In the under-hood fuse/relay box) • Faulty combination light switch • An open in the wire
B9	—	Ignition switch ON	Check for voltage to ground: There should be battery voltage.	<ul style="list-style-type: none"> • Blown No.13 (10 A) fuse (In the under-dash fuse box)
B8	—	Driver's door open	Check for continuity to ground: There should be continuity. NOTE: Before testing, remove the No.46 (15 A) fuse from the under-hood fuse/relay box.	<ul style="list-style-type: none"> • Faulty driver's door switch • An open in the wire
A3	ORN	Ignition switch ON; connect the B9 terminal to the A3 terminal.	Check chime operation: Chime should activate each time the battery is connected.	<ul style="list-style-type: none"> • Faulty chime • An open in the wire

(cont'd)

Integrated Control Unit (KM model)

Input Test (cont'd)

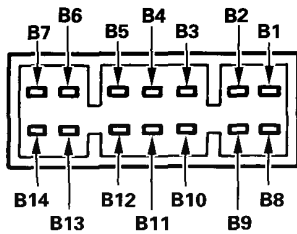

View from terminal side of the under-dash fuse box socket

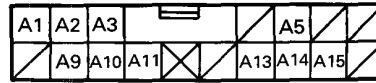

View from wire side of the harness connector

Rear Window Defogger Timer Circuit:

Terminal No.	Wire	Test condition	Test: Desired result	Possible cause if result is not obtained
B1	—	Under all conditions	Check for continuity to ground: There should be continuity.	<ul style="list-style-type: none"> • Poor ground (G401, G402) • An open in the wire
B13	—	Defogger switch pushed	Check for continuity to ground: There should be continuity as the switch is pushed.	<ul style="list-style-type: none"> • Faulty defogger switch • Poor ground (G401, G402) • An open in the wire
B12	—	Ignition switch ON	Attach to ground: Rear window defogger should work and the defogger switch indicator light should come on.	<ul style="list-style-type: none"> • Blown No.34 (40 A) fuse (In the under-hood fuse/relay box) • Faulty defogger relay • Blown LED • An open in the wire
B9	—	Ignition switch ON	Check for voltage to ground: There should be battery voltage.	<ul style="list-style-type: none"> • Blown No.13 (10 A) fuse (In the under-dash fuse box)

Engine Oil Pressure Indicator Flasher System:

Terminal No.	Wire	Test condition	Test: Desired result	Possible cause if result is not obtained
B1	—	Under all conditions	Check for continuity to ground: There should be continuity.	<ul style="list-style-type: none"> • Poor ground (G401, G402) • An open in the wire
B9	—	Ignition switch ON	Check for voltage to ground: There should be battery voltage.	<ul style="list-style-type: none"> • Blown No.13 (10 A) fuse (In the under-dash fuse box)
A2	WHT/BLU ¹	Engine running	Check for voltage to ground: There should be battery voltage.	<ul style="list-style-type: none"> • Faulty charging system • An open in the wire
A1	YEL/RED	Ignition switch OFF	Check for continuity to ground: There should be continuity.	<ul style="list-style-type: none"> • Faulty engine oil pressure switch • An open in the wire
		Ignition switch ON	Check indicator light. If the light does not come on, connect the A1 terminal to ground: The light should come on as the ignition switch is turned ON.	<ul style="list-style-type: none"> • Blown bulb • An open in the wire
		Start the engine.	Check for voltage to ground: There should be battery voltage.	<ul style="list-style-type: none"> • Insufficient oil • Improper lubrication • Faulty engine oil pressure switch

Lights-on Reminder System (KM model)



Chime Test

NOTE:

Refer to page 23-15 for the diagram of the lights-on reminder circuit, and page 23-19 for the input test of the circuit.

When the ignition key is turned to the "0" position and removed, with the lights on, voltage is applied to the reminder circuit in the integrated control unit. When you open the driver's door, the circuit senses ground through the closed door switch.

With voltage at the "B6" terminal, ground at the "B8" terminal and no voltage at the "B9" terminal, the chime sounds to remind the driver to turn off the lights.

1. Remove the dashboard lower cover and knee bolster.
2. Disconnect the 2-P connector from the main wire harness.

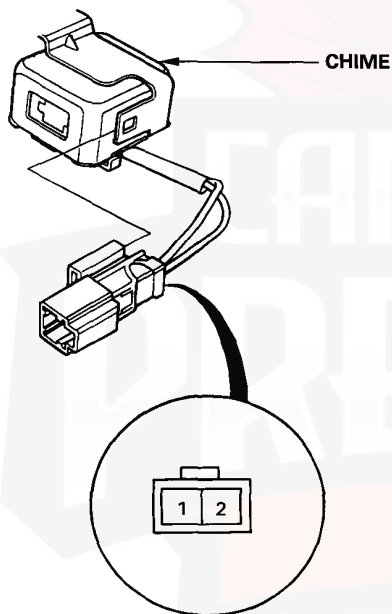

3. Test the chime by connecting battery power to the No.1 terminal, grounding the No.2 terminal, and cycling the power on-off repeatedly.
4. If the chime fails to sound every time power is cycled, replace it.

Stereo Sound System

Antenna Tube Replacement

NOTE:

The reference pages given below refer to the Prelude Shop Manual 62SS000.

1. Remove the antenna mast (see page 23-281).
2. Remove the antenna tube/motor assembly (see page 23-282).
3. Remove the tube clamping screw, and pull the antenna tube out of the motor.
4. Remove the plastic guide and plastic insulator tube, and install them in the new antenna tube.

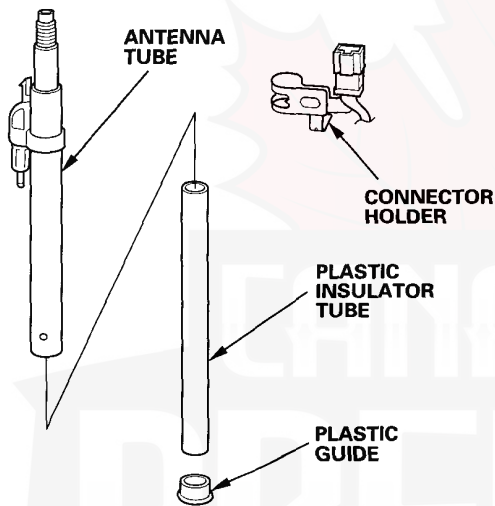

5. Insert the new antenna tube.

With an alignment mark:

- Insert the new antenna tube into the motor, and align the mark on the tube with the screw that is used to clamp the tube to the motor.

Without an alignment mark:

- Insert only the tube, and install the tube/motor assembly in the car.
- Adjust the tube so that the collar fits properly against the body, and mark the tube and motor.
- Remove the tube/motor assembly again.
- Align the mark on the tube with the mark on the motor, and tighten the clamping screw.

With an alignment mark:

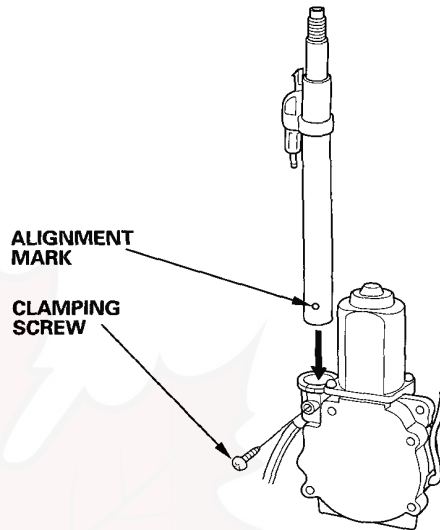

Without an alignment mark:

When the alignment is correct, mark the tube and motor.

Adjust the tube so that the collar fits the contour of the body.

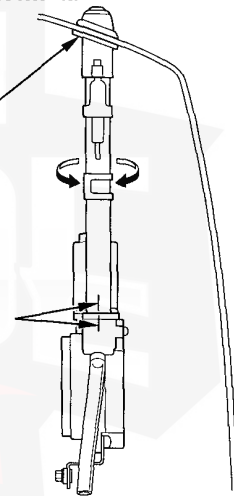

6. Install the tube/motor assembly to the car (see page 23-282).
7. Insert the mast into the tube (see page 23-281).



Antenna Mast Installation

1. Carefully direct the teeth of the antenna mast drive cable as shown, and insert the drive cable into the antenna housing.

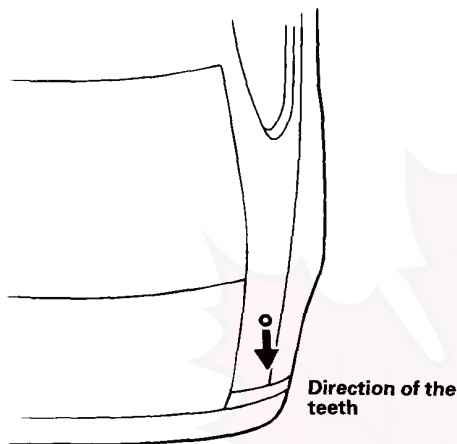

2. Check for engagement of the cable teeth to the drive gear by carefully moving the cable up and down.
3. Clean the antenna mast housing threads.
4. Turn the radio switch "OFF", and let the motor pull the drive cable inside the antenna housing.
5. Install the bushing and spacer.

6. Tighten the antenna nut.
2.3 N·m (0.23 kg-m, 1.7 lb-ft)

NOTE:

There are two types of antenna nuts – those with an O-ring (new type) and those without an O-ring (old type) – which require different spacers. To prevent a leak, make sure that

- there is no antenna collar seal in the antenna collar when using a nut with an O-ring. If necessary, remove the seal.
- there is an antenna collar seal in the antenna collar when using a nut without an O-ring. If necessary, install a seal.
- the spacer matches the type of antenna nut.

With O-ring:

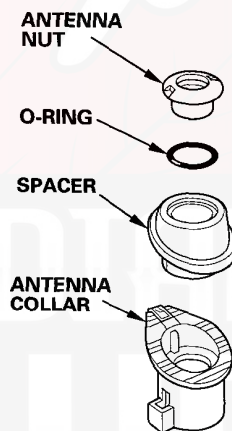

Without O-ring:

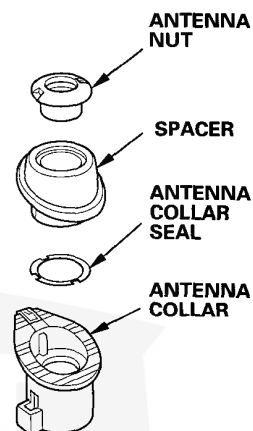

7. Check that the antenna mast extends and retracts fully when the radio switch is turned ON and OFF repeatedly. If you overtighten the nut, the antenna may stick. If sticking occurs, back the nut off a little, then raise and lower the antenna again. Repeat until the antenna moves freely.

Power Mirror

Actuator Replacement

1. Remove the door mirror assembly from the door, and disconnect the connector.
2. Cut the wire harness just above the connector with wire cutters, then remove the vinyl tape.

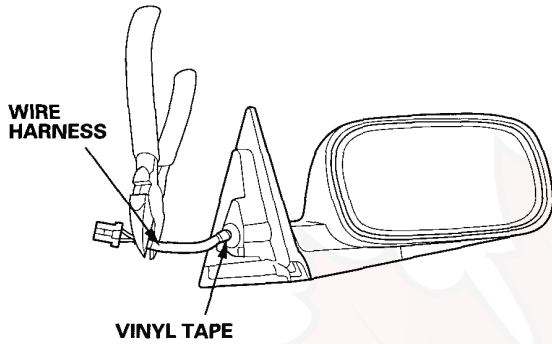

3. Remove the gasket from the mirror base, then remove the hook plate to release the harness.

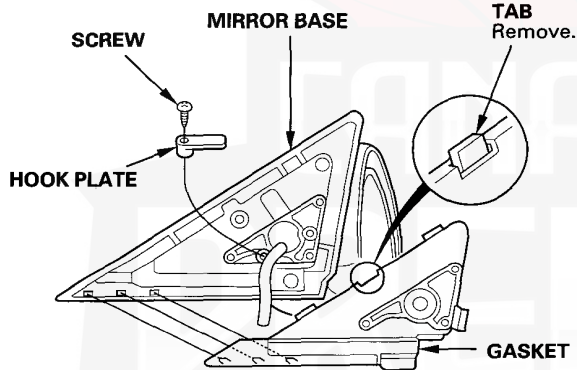

4. Remove the four screws from the mirror base, then remove the mirror housing.

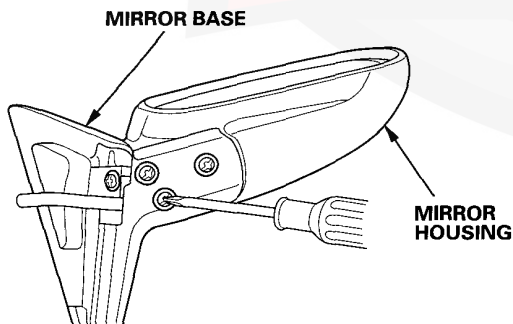

5. Insert a flat tip screwdriver into the groove between the mirror housing and the mirror holder, then pry off the mirror.

NOTE:

Be careful not to damage the mirror housing.

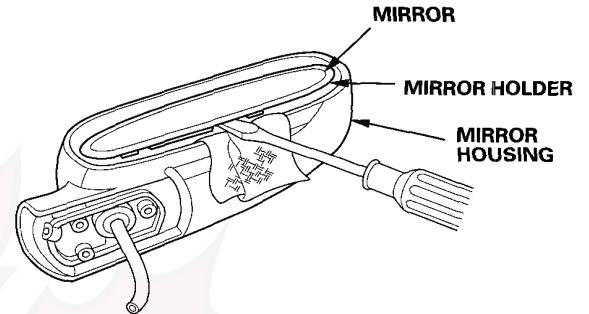

6. With defogger: Push the lock button, and remove the defogger connector.

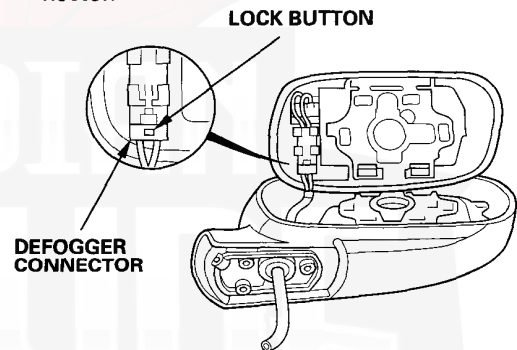

7. Remove the three screws attaching the actuator to the frame, then remove the actuator.

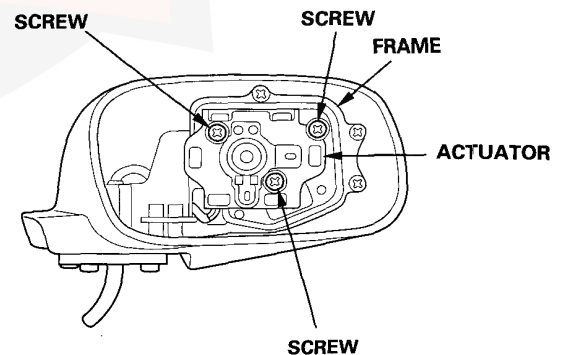



8. Route the harness of the new actuator through the frame hole and the shaft hole, and position the actuator onto the frame.

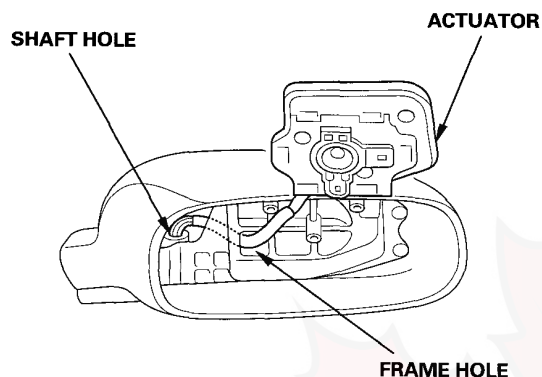

9. Reassemble in the reverse order of disassembly, and tape the wire harness where it leaves the gasket.

NOTE:
Be careful not to break the mirror when reinstalling it to the actuator.

10. Referring to the table below, reconnect the wire harness to the connector.

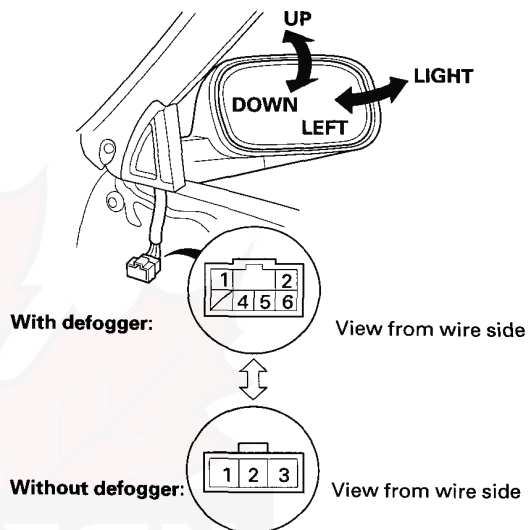

No.	Wire Color			
	With defogger		Without defogger	
	Left	Right	Left	Right
1	BLU/RED	BLU/RED	BLU	BLU
2	BLK/WHT	BLK/WHT	BRN	BRN
3	—	—	YEL	YEL
4	BLU	BLU	—	—
5	BRN	BRN	—	—
6	YEL	YEL	—	—

11. Reinstall the mirror assembly to the door, and re-connect the connector.
12. Operate the power mirror to check that the actuator works smoothly.

Power Windows (With Key-off Timer for KM model)

Component Location Index

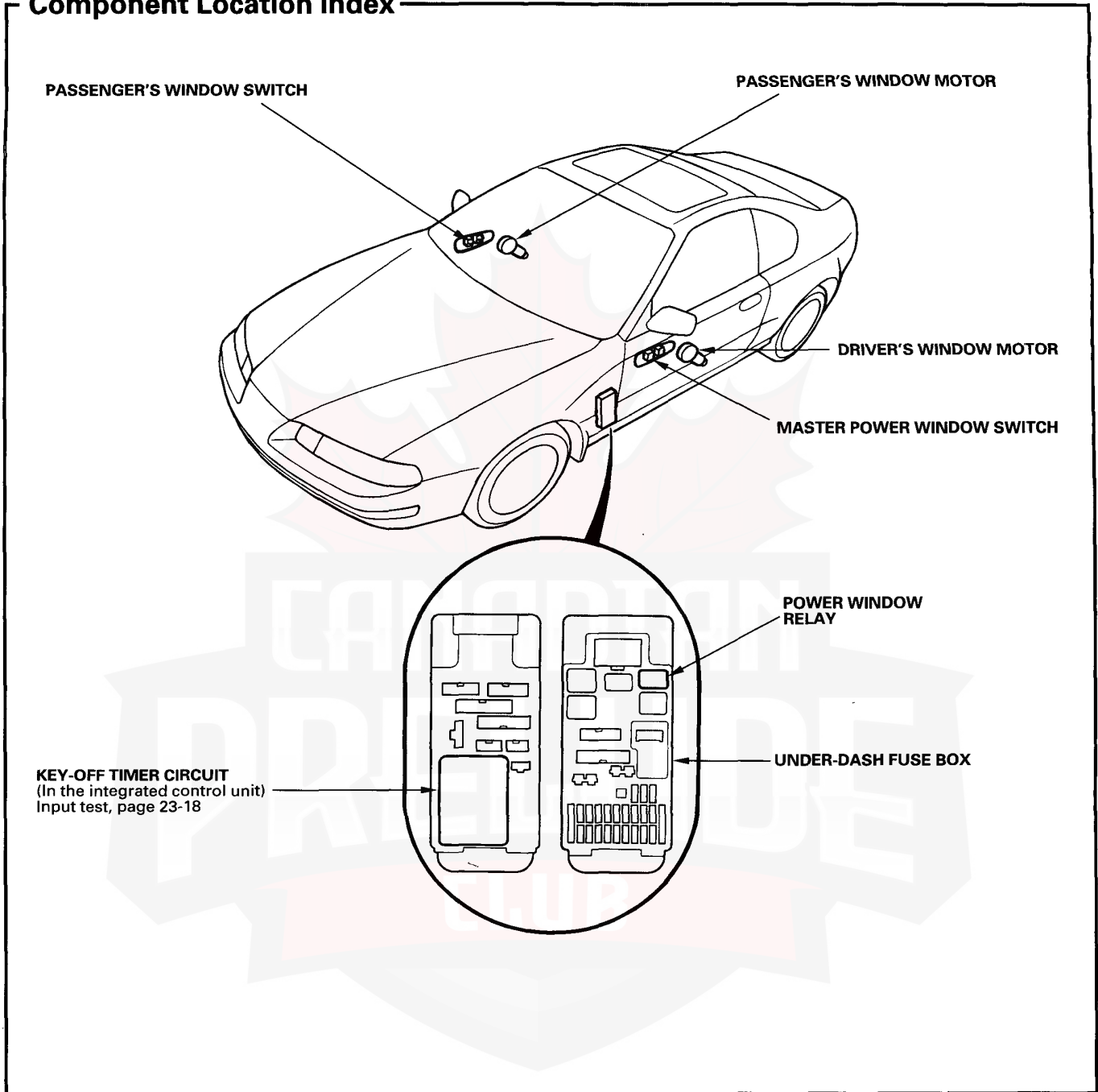

Description

Power Window/Sunroof Key-off Timer Operation:

The power windows/sunroof can still be operated for about 10 minutes after the ignition switch is turned from the "II" to the "I" or "O" position as long as neither door has been opened. This provides a convenience to parked occupants.



Circuit Diagram

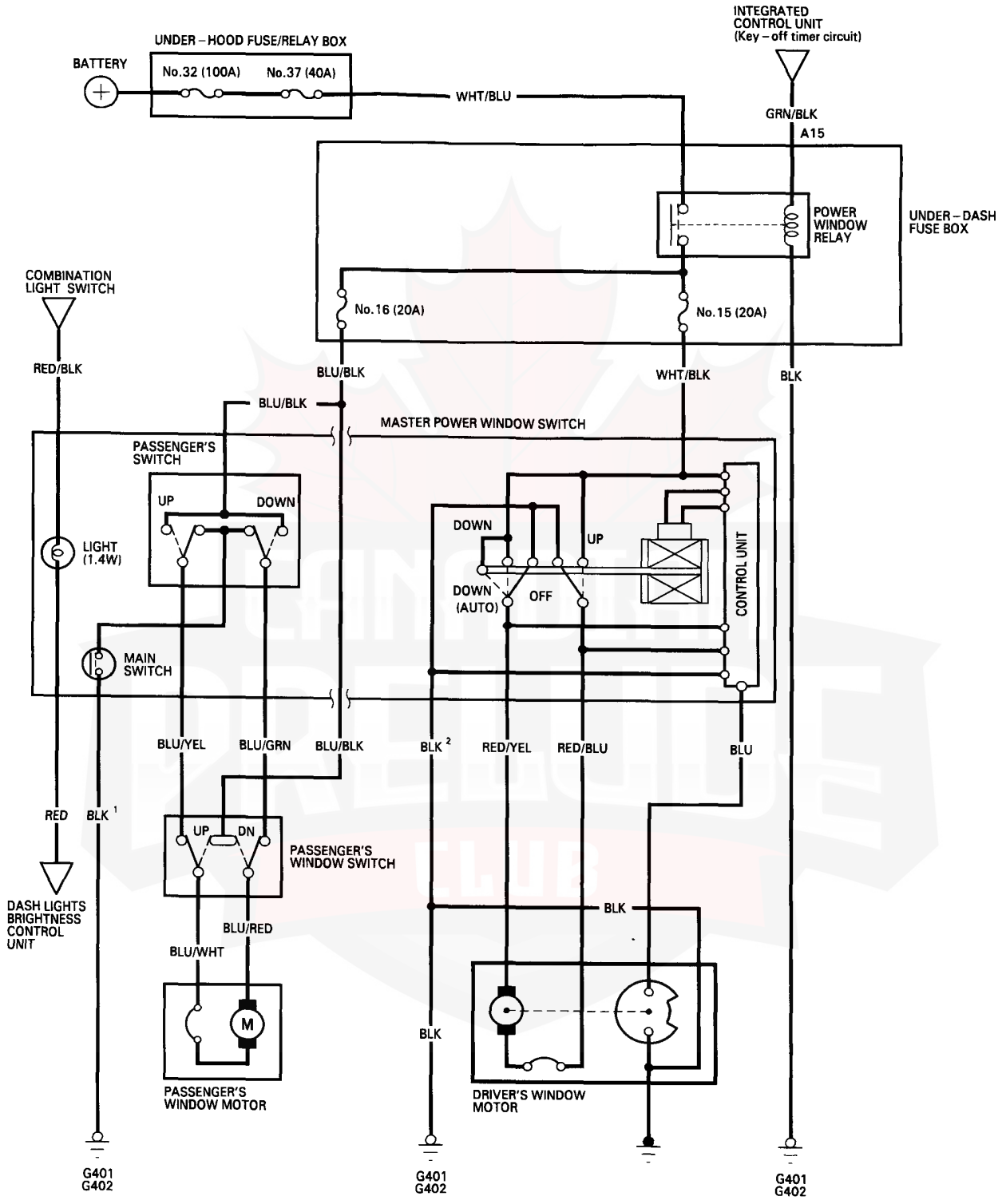



Sunroof (With Key-off Timer for KM model)

Circuit Diagram

